

MCUXpresso SDK 3-Phase PMSM Control (i.MX RT)



Contents

Chapter 1 Introduction..... 3

Chapter 2 Hardware setup..... 4

Chapter 3 RT crossover processors features and peripheral settings..... 18

Chapter 4 Project file and IDE workspace structure..... 30

Chapter 5 Tools..... 32

Chapter 6 Motor-control peripheral initialization..... 33

Chapter 7 User interface..... 35

Chapter 8 Remote control using FreeMASTER..... 36

Chapter 9 Identifying parameters of user motor using MCAT..... 44

Chapter 10 Conclusion..... 63

Chapter 11 Acronyms and abbreviations..... 64

Chapter 12 References..... 65

Chapter 13 Useful links..... 66

Chapter 14 Revision history..... 67

Chapter 1

Introduction

This user's guide describes the implementation of the sensorless motor-control software for 3-phase Permanent Magnet Synchronous Motors (PMSM), including the motor parameters identification algorithm, on the NXP i.MX RT series crossover processors. The sensorless control software and the PMSM control theory in general are described in design reference manual [DRM148 Sensorless PMSM Field-Oriented Control \(FOC\)](#). The NXP Freedom ([FRDM-MC-LVPMSM](#)) is used as the hardware platform for the PMSM control reference solution. The hardware-dependent part of the sensorless and sensed control software, including a detailed peripheral setup and the Motor Control (MC) peripheral drivers, are addressed as well. The motor parameters identification theory and algorithms are presented in this document. The last part of the document introduces and explains the user interface represented by the Motor Control Application Tuning ([MCAT](#)) page based on the FreeMASTER run-time debugging tool. These tools provide a simple and user-friendly way for the motor parameter identification, algorithm tuning, software control, debugging, and diagnostics.

This document describes how to run and control the Permanent Magnet Synchronous Motor (PMSM) project using [i.MX RT Series Crossover Processors](#) with the Freedom development board. The software provides sensorless/sensed field-oriented vector position, speed, torque, and scalar control. You can control the application using the board buttons or via FreeMASTER. The motor identification and application tuning is done using the MCAT tool integrated in the FreeMASTER page. The required software, hardware setup, jumper settings, project arrangement, and user interface are described in the following sections. For more information, visit www.nxp.com/motorcontrol_pmsm.

Table 1. Supported devices and control methodes

Device	Default motor	Possible control methods in SDK example					
		Scalar	Voltage	Current FOC (Torque)	Sensorless Speed FOC	Sensed Speed FOC	Sensed Position FOC (Servo)
MIMXRT1024-EVK	Teknic M-2310P motor (with ENC)	✓	✓	✓	✓	✓	✓
MIMXRT1060-EVK	Teknic M-2310P motor (with ENC)	✓	✓	✓	✓	✓	✓
MIMXRT1060-EVKB	Teknic M-2310P motor (with ENC)	✓	✓	✓	✓	✓	✓
MIMXRT1064-EVK	Teknic M-2310P motor (with ENC)	✓	✓	✓	✓	✓	✓
MIMXRT1160-EVK	Teknic M-2310P motor (with ENC)	✓	✓	✓	✓	✓	✓
MIMXRT1170-EVK	Teknic M-2310P motor (with ENC)	✓	✓	✓	✓	✓	✓

Chapter 2

Hardware setup

The PMSM Field-Oriented Control (FOC) application runs on the FRDM-MC-LVPMSM development platform with the i.MX RT1020-EVK, i.MX RT1050-EVKB, and i.MX RT1060-EVK development tools in combination with the Teknic M-2310P-LN permanent magnet synchronous motor or with the i.MX RT1010-EVK development tool in combination with the Linix 45ZWN24-40 permanent magnet synchronous motor.

2.1 FRDM-MC-LVPMSM

This evaluation board, in a shield form factor, effectively turns an NXP Freedom development board or an evaluation board into a complete motor-control reference design, compatible with existing NXP Freedom development boards and evaluation boards. The Freedom motor-control headers are compatible with the Arduino™ R3 pin layout.

The FRDM-MC-LVPMSM low-voltage, 3-phase Permanent Magnet Synchronous Motor (PMSM) Freedom development platform board has the power supply input voltage of 24-48 VDC with a reverse polarity protection circuitry. The auxiliary power supply of 5.5 VDC is created to supply the FRDM MCU boards. The output current is up to 5 A RMS. The inverter itself is realized by a 3-phase bridge inverter (six MOSFETs) and a 3-phase MOSFET gate driver. The analog quantities (such as the 3-phase motor currents, DC-bus voltage, and DC-bus current) are sensed on this board. There is also an interface for speed and position sensors (encoder, hall). The block diagram of this complete NXP motor-control development kit is shown in [Figure 1](#).

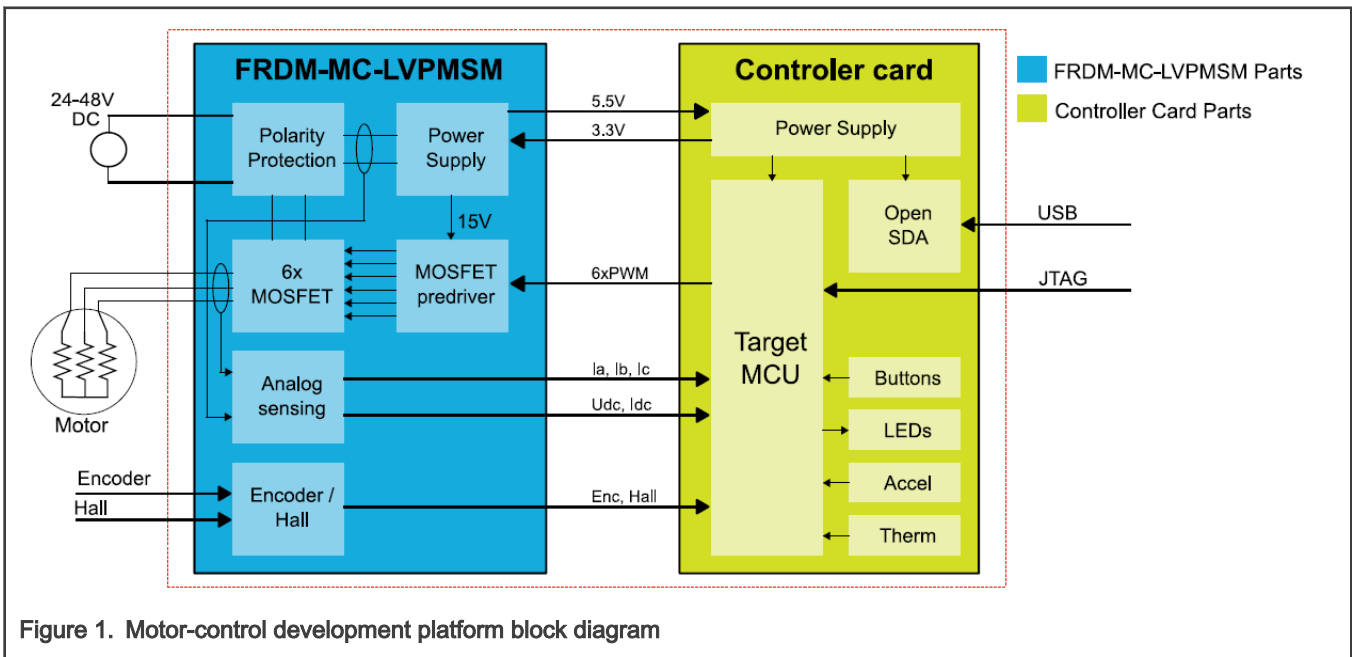

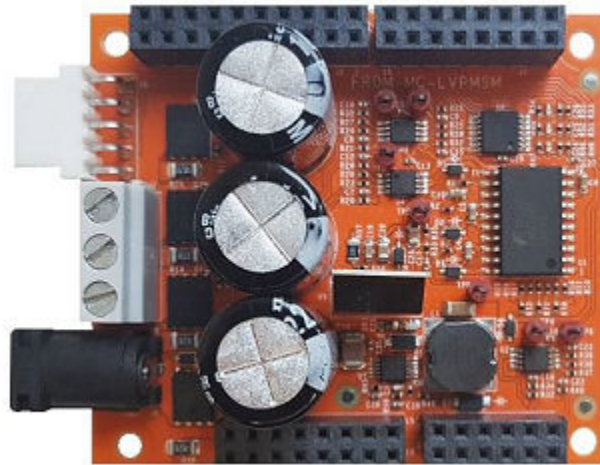

Figure 2. FRDM-MC-LVPMSM

The FRDM-MC-LVPMSM board does not require a complicated setup. For more information about the Freedom development platform, see www.nxp.com.

2.2 Teknic M-2310P motor

The Teknic M-2310P-LN-04K motor is a low-voltage 3-phase permanent-magnet motor used in PMSM applications. The motor has two feedback sensors (hall and encoder). For information on the wiring of feedback sensors, see the datasheet on the manufacturer web page. The motor parameters are listed in [Table 2](#).

Table 2. Teknic M-2310P motor parameters

Characteristic	Symbol	Value	Units
Rated voltage	Vt	40	V
Rated speed	-	6000	RPM
Rated torque	T	0.247	Nm
Rated power	P	170	W
Continuous current	Ics	7.1	A
Number of pole-pairs	pp	4	-



Figure 3. Teknic M-2310P permanent magnet synchronous motor

For the sensorless control mode, you need only the power input wires. If used with the hall or encoder sensors, connect also the sensor wires to the NXP Freedom power stage.

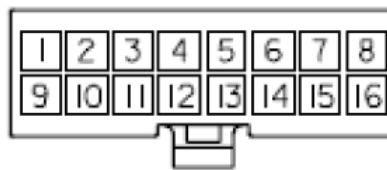

(Wire Entry View)

Pin	Color	Signal	Pin	Color	Signal
1	DRAIN x3	P DRAIN	9	16AWG BLK	PHASE R
2	N/A	N/A	10	16AWG RED	PHASE S
3	GRN	COMM S-T	11	16AWG WHT	PHASE T
4	GRN/WHT	COMM R-S	12	RED	+5VDC IN
5	GRY/WHT	COMM T-R	13	BRN	ENC I
6	DRAIN x1	E DRAIN	14	ORN	ENC B
7	BLK	GND	15	BLU	ENC A
8*	BLU/WHT	ENC A~	16*	ORN/WHT	ENC B~

Motor phases

Encoder wires

Figure 4. Teknic motor connector type 1

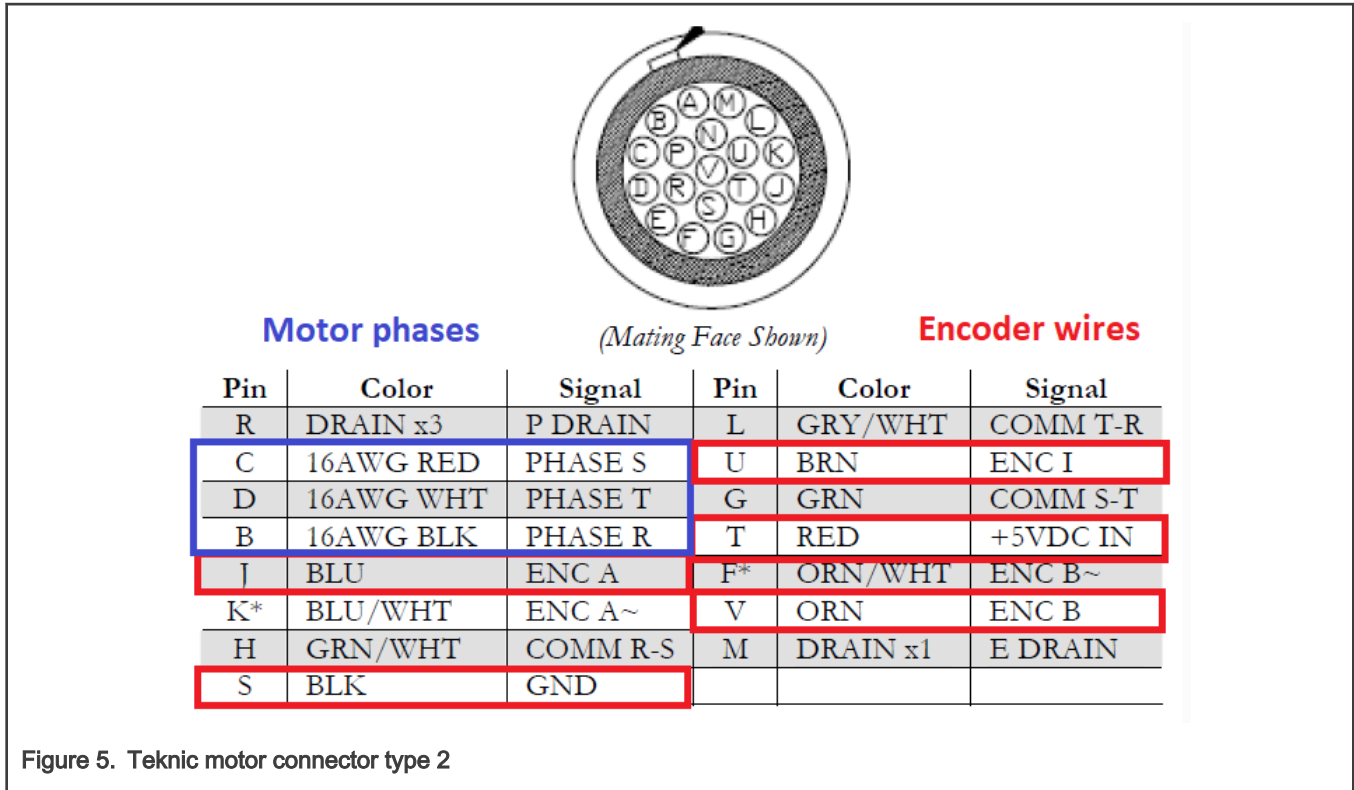

2.3 i.MX RT1024 evaluation kit (MIMXRT1024-EVK)

[MIMXRT1024-EVK](#) board is a platform designed to showcase the most commonly used features of the i.MX RT1024 Processor in a small, low cost package. The MIMXRT1024 EVK board is an entry-level development board, which gives the developer the option of becoming familiar with the processor before investing a large amount of resources in more specific designs.

Table 3. MIMXRT1024-EVK jumper settings

Jumper	Setting	Jumper	Setting	Jumper	Setting
J1	5-6	J8	1-2	J47	1-2
J3	1-2	J37	1-2	J48	1-2
J4	1-2	J43	1-2	J49	1-2
J5	1-2	J45	1-2	J50	1-2
J6	1-2	J46	1-2		

All others jumpers are open.

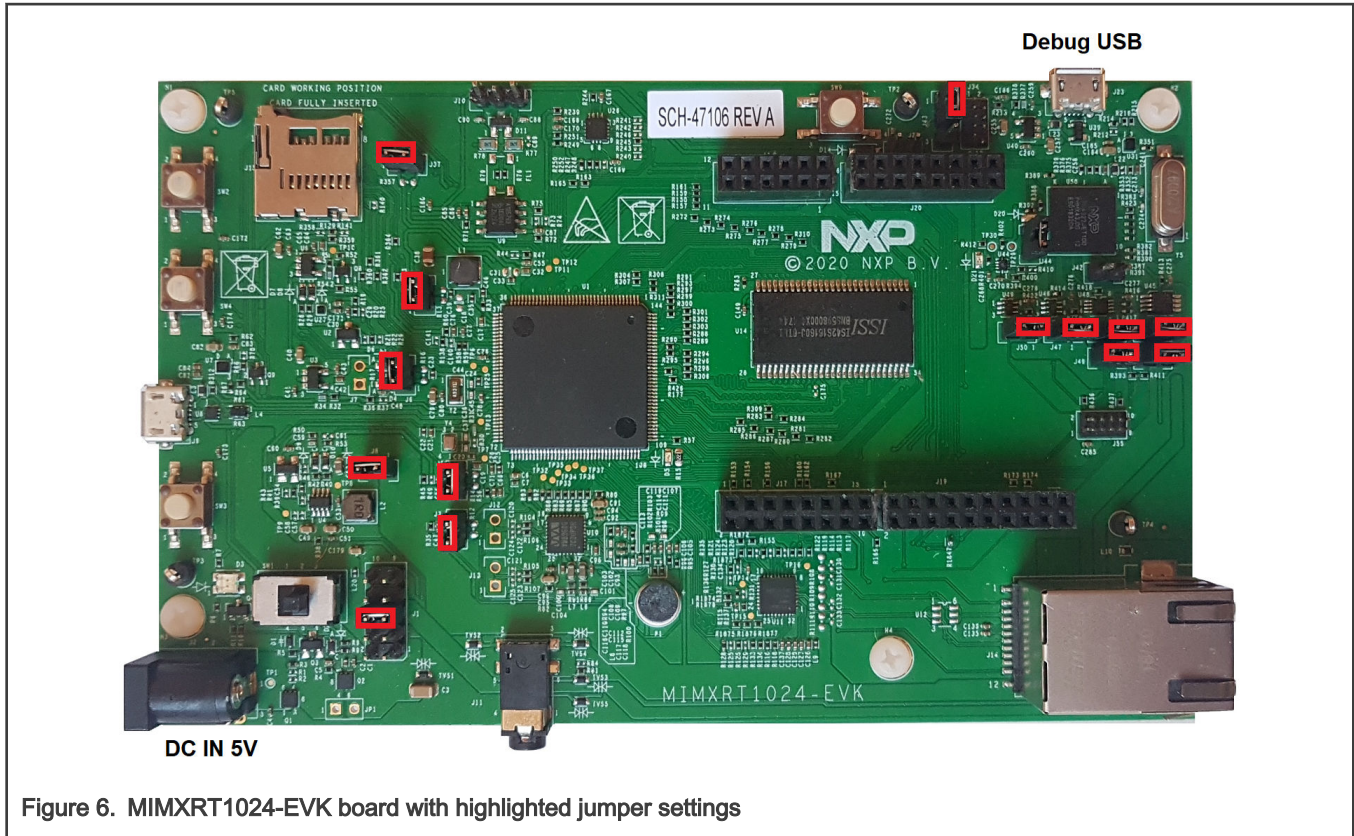

For correct board working are needed solder and remove several resistors. Please, solder resistors R1843, R1844, R1845, R1846, R1847 and if you will use encoder, solder also R1841 and R1847. For proper encoder working, please remove resistor R1870 shared with USER LED. The resistor R1847 is located on the top side of EVK next to J19. All others resistor are located on the bottom EVK side. For more details, see the [schematic](#).

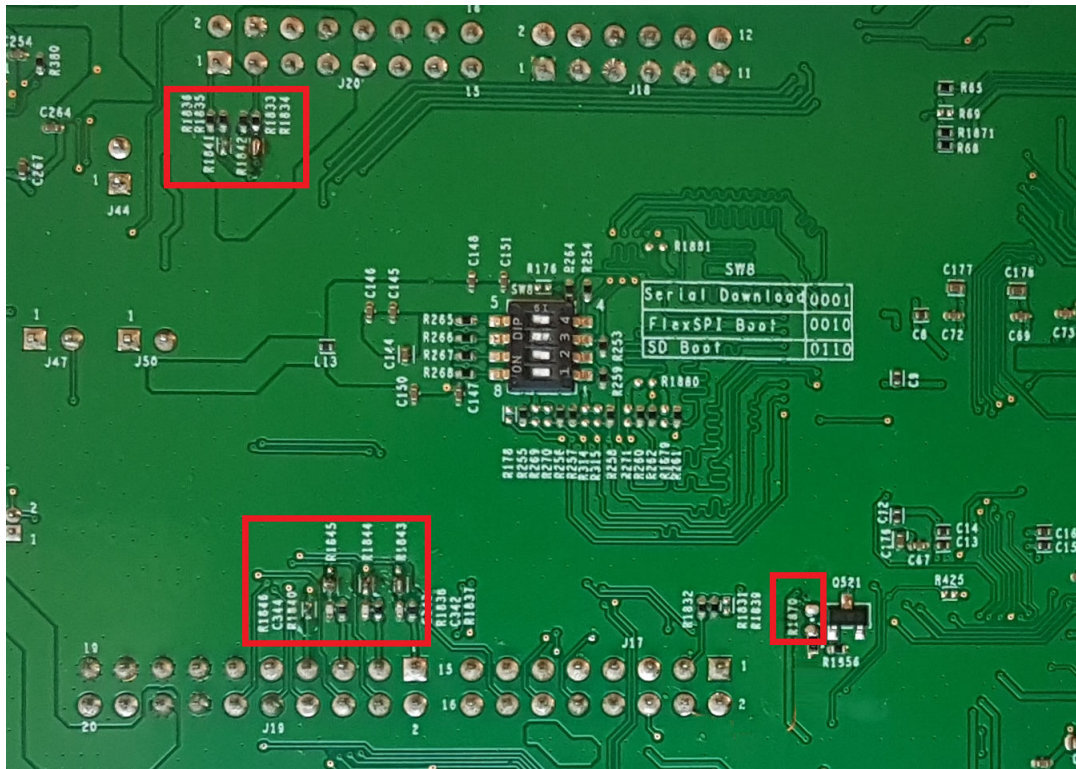

Figure 7. Removed resistor for proper operation of the ADC on the bottom side of the EVK board

For more information about the MIMXRT1024-EVK hardware (processor, peripherals, and so on), see the *MIMXRT1024 EVK Board Hardware User's Guide* (document [MIMXRT1024EVKHUG](#)).

Hardware assembling

1. Connect the FRDM-MC-LVPMSM shield on top of the MIMXRT1024-EVK board (there is only one possible option).
2. Connect the 3-phase motor wires to the screw terminals (J7) on the Freedom PMSM power stage.
3. Plug the USB cable from the USB host to the Debug USB connector (J23) on the EVK board.
4. Plug the 24-V DC power supply to the DC power connector on the Freedom PMSM power stage.

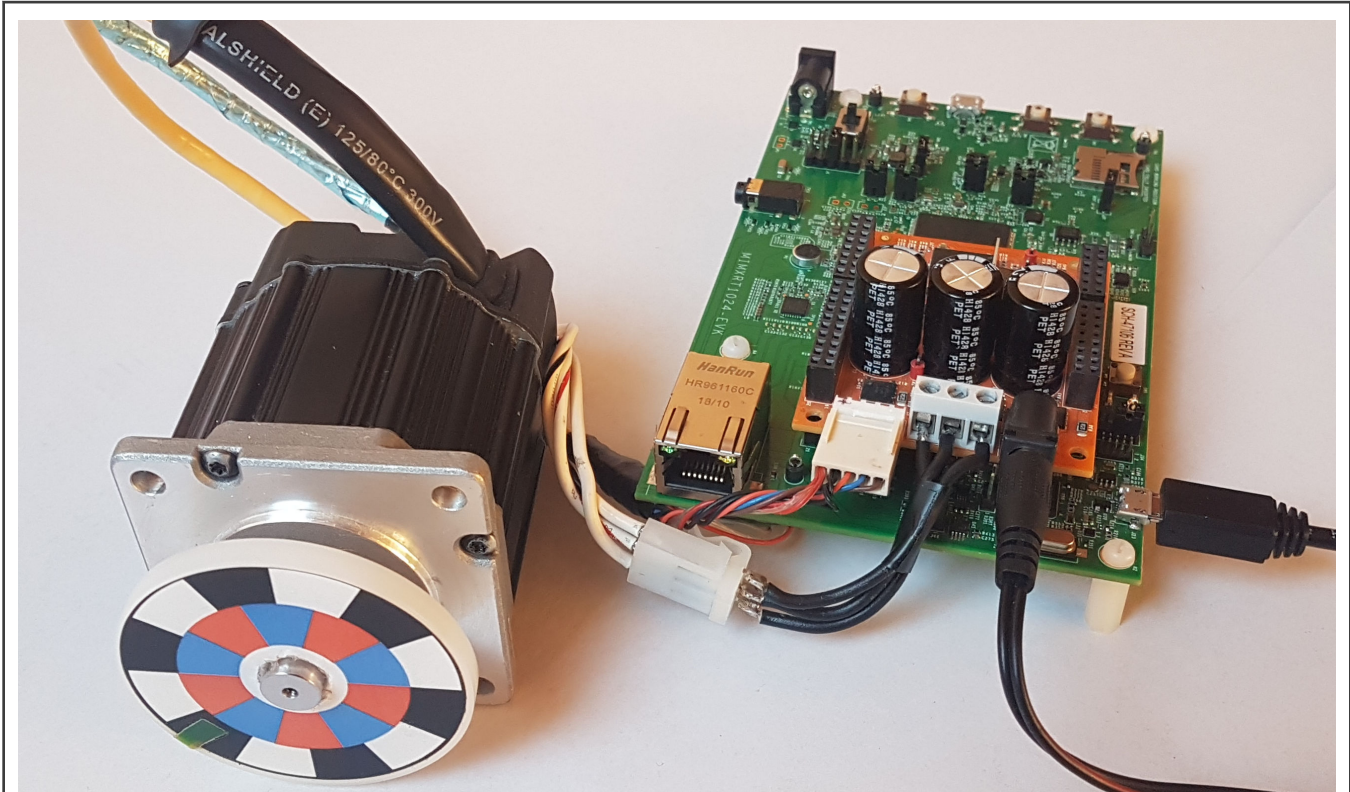

Figure 8. Assembled Freedom system

2.4 i.MX RT1060/1064 Evaluation Kit (MIMXRT1060-EVK, MIMXRT1060-EVKB, MIMXRT1064-EVK)

MIMXRT1060-EVK, MIMXRT1060-EVKB and MIMXRT1064-EVK are a 4-layer, hole-through, USB-powered PCBs. It includes the i.MX RT106x crossover processor, featuring NXP’s advanced implementation of the Arm Cortex-M7 core. This cores operates at up to 600 MHz to provide high CPU performance and the best real-time response.

Table 4. MIMXRT1060-EVK, MIMXRT1060-EVKB and MIMXRT1064-EVK jumper settings

Jumper	Setting	Jumper	Setting	Jumper	Setting
J1	5-6	J13	open	J44	1-2
J3	1-2	J15	open	J47	1-2
J4	1-2	J26	open	J48	1-2
J5	1-2	J36	1-2	J49	1-2
J7	1-2	J43	1-2	J50	1-2

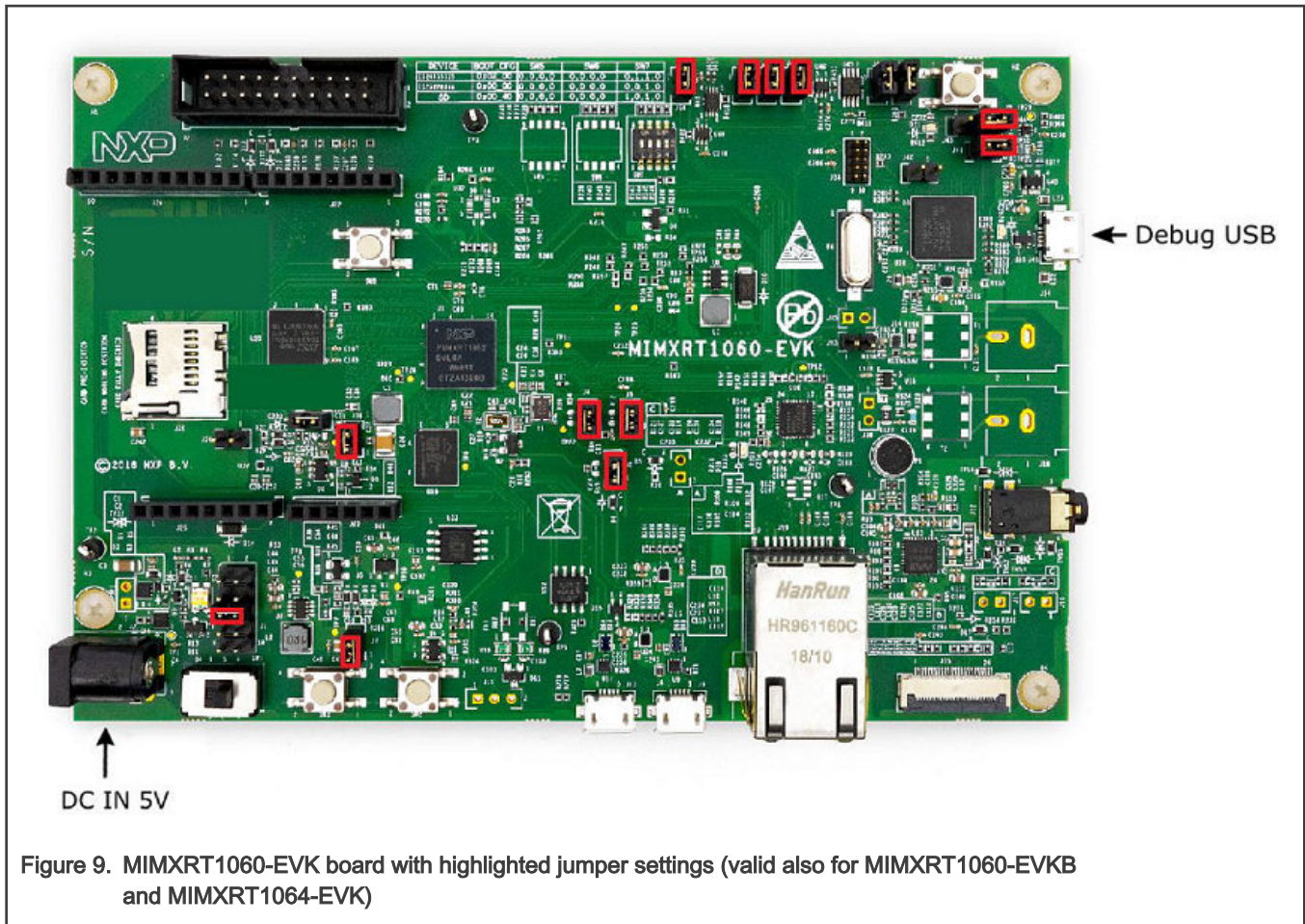

The motor-control application requires the PWM signals to be connected from the MCU to the power stage. For a correct connection, solder the R278, R279, R280, and R281 resistors to the board. These resistors are located on the bottom side of the EVK board. For more details, see the schematic.

Table 5. MIMXRT1060-EVK, MIMXRT1060-EVKB and MIMXRT1064-EVK pin assignment (continued)

FRDM-MC-LVPMSM	Connection	MIMXRT1060-EVK, MIMXRT1060-EVKB, MIMXRT1064-EVK	
ENC_A	J3, 3 <-> J24, 1	D8/CLKO/ICP1	GPIO_AD_B0_03
ENC_B	J3, 1 <-> J24, 2	D9/OC1A/PWM	GPIO_AD_B0_02
GND	3, 14 <-> J25, 6	GND	GND
CUR_A	J2, 1 <-> J23, 2	A1/ADC1	GPIO_AD_B1_11
CUR_B	J2, 3 <-> J23, 6	A5/ADC5/SCL	GPIO_AD_B1_00
CUR_C	J2, 5 <-> J23, 5	A4/ADC4/SDA	GPIO_AD_B1_01
VOLT_DCB	J2, 7 <-> J22, 7	D6/AIN0/PWM/OC0A	GPIO_AD_B1_02
CUR_DCB	J2, 9 <-> J22, 8	D7/AIN1/PWM	GPIO_AD_B1_03

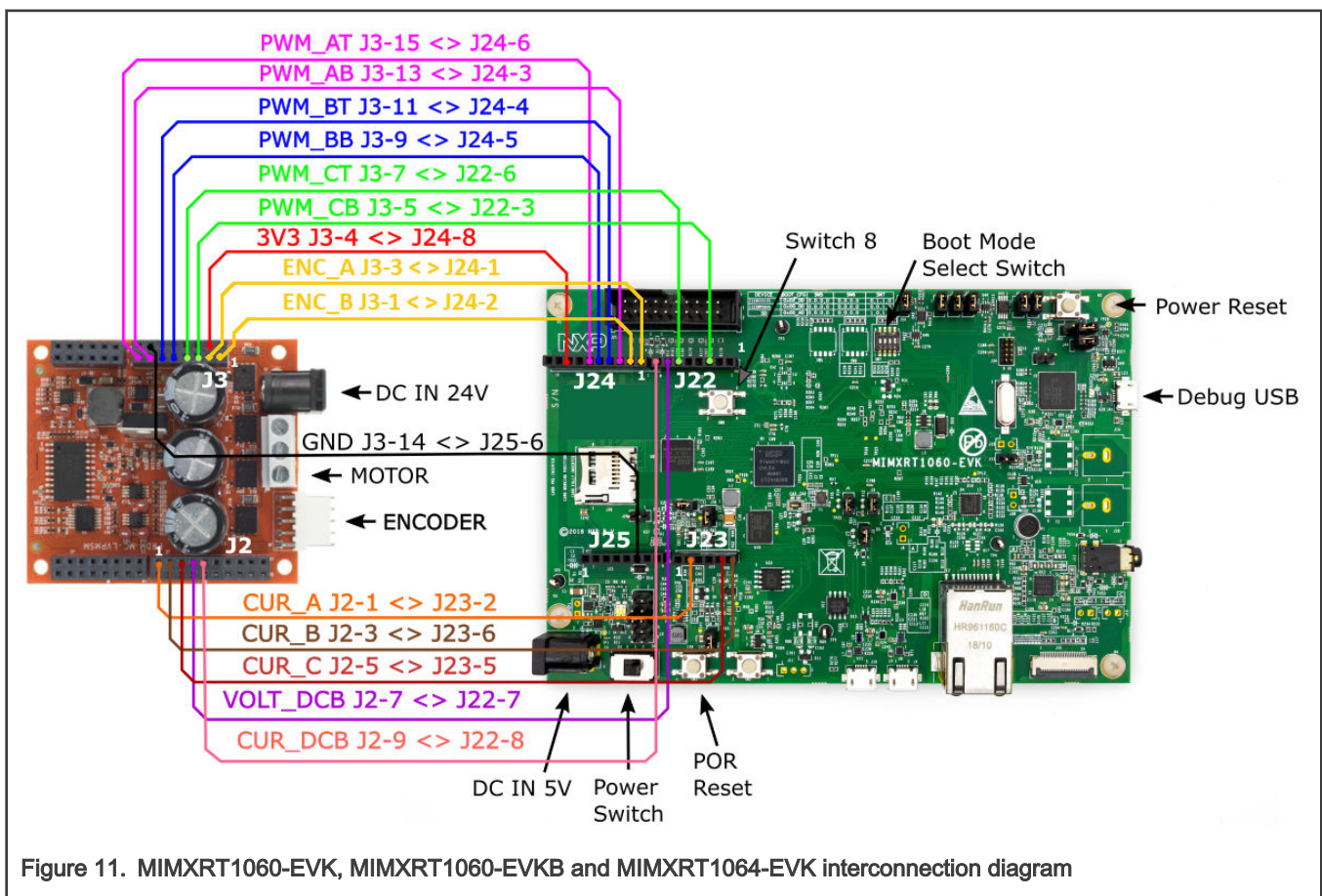

Figure 11. MIMXRT1060-EVK, MIMXRT1060-EVKB and MIMXRT1064-EVK interconnection diagram

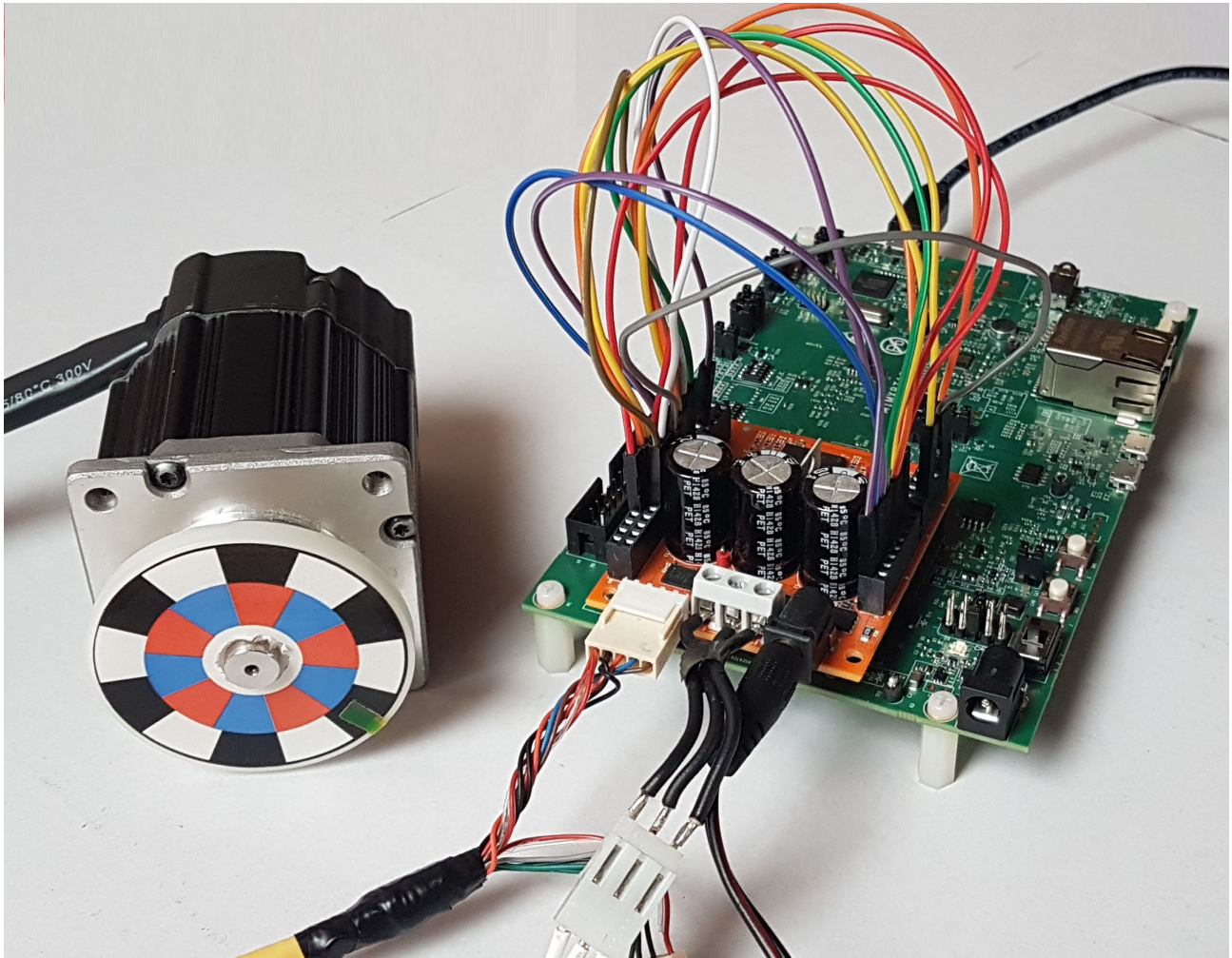

Figure 12. Assembled Fredome system

2.5 i.MX RT1160/1170 Evaluation Kit

The [MIMXRT1160-EVK](#) and [MIMXRT1170-EVK](#) are two-layer low-cost through-hole USB-powered PCBs. At its heart lies the i.MX RT11xx crossover MCU. The dual core i.MX RT1160 runs on the Cortex-M7 core at 600 MHz and Arm Cortex-M4 at 240 MHz and i.MX RT1170 runs on the Cortex-M7 core at 1 GHz and Arm Cortex-M4 at 400 MHz, while providing best-in-class security.

Table 6. MIMXRT1160-EVK and MIMXRT1170-EVK jumper settings

Jumper	Setting	Jumper	Setting	Jumper	Setting
J5	1-2	J31	1-2	J59	1-2
J6	1-2	J32	1-2	J60	1-2
J7	1-2	J38	5-6	J61	1-2
J8	1-2	J41	1-2	J62	1-2
J21	1-2	J53	1-2		
J27	2-3	J56	2-3		

All others jumpers are open.

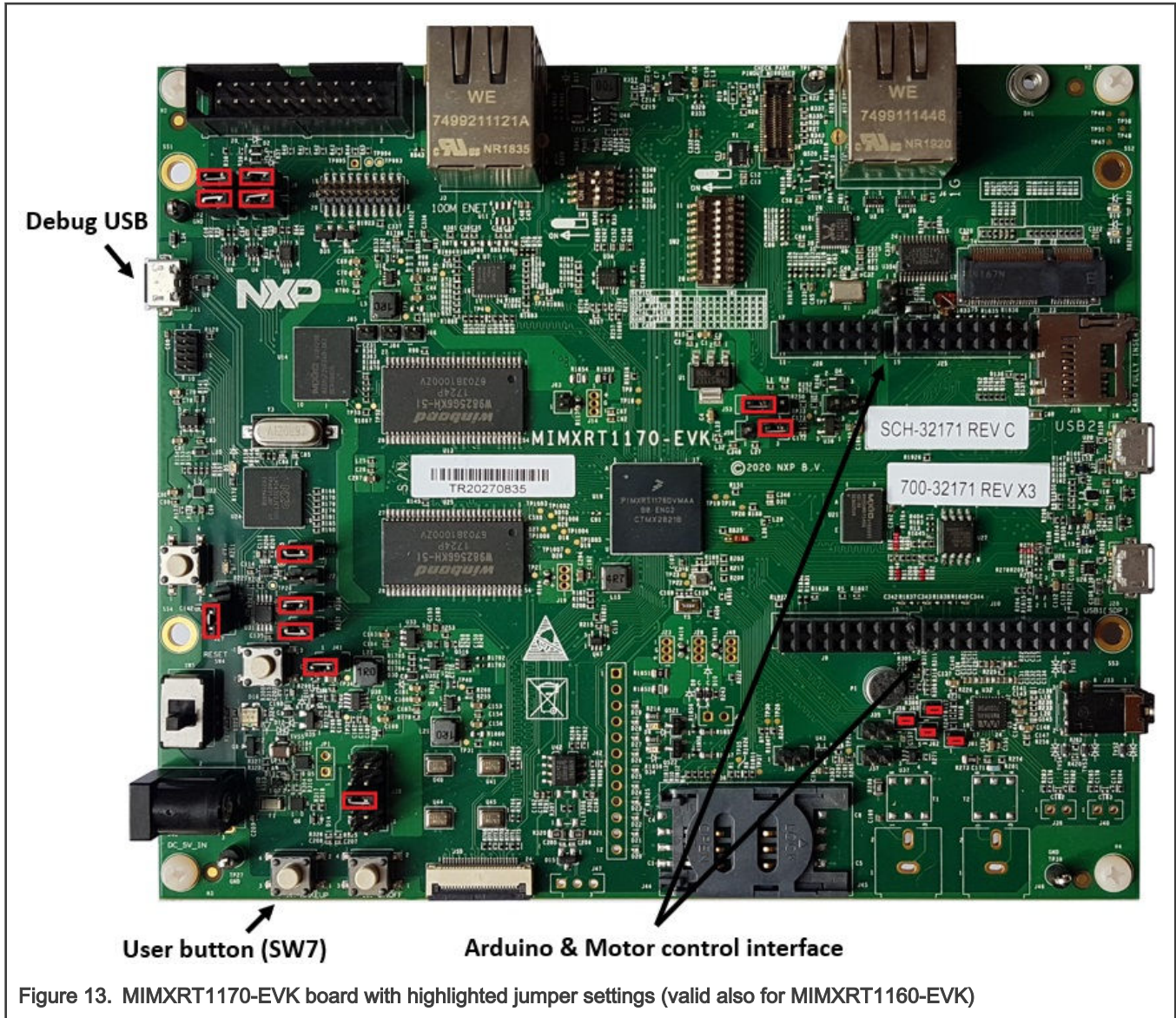

Figure 13. MIMXRT1170-EVK board with highlighted jumper settings (valid also for MIMXRT1160-EVK)

For a correct connection, the motor-control application requires remove and solder some resistors. Please, solder resistor R1841 and R1842 for encoder and remove resistors R188 and R193 for right ADC measuring. These resistors are located on the top of the EVK board. For more details, see the schematic.

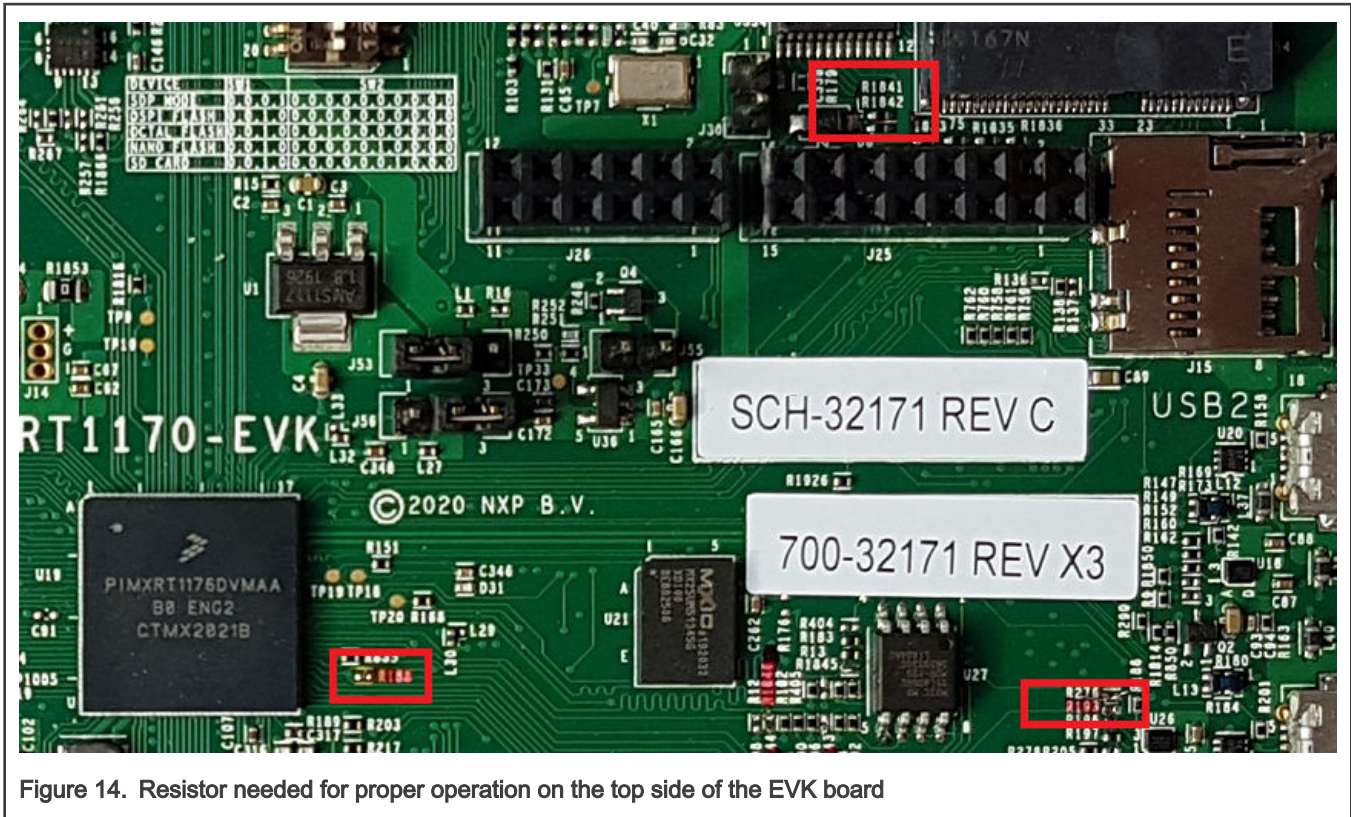

Figure 14. Resistor needed for proper operation on the top side of the EVK board

For more information about the MIMXRT1160-EVK or MIMXRT1170-EVK hardware (processor, peripherals, and so on), see the [MIMXRT1160 EVK Board Hardware User's Guide](#) or [MIMXRT1170 EVK Board Hardware User's Guide](#).

Hardware assembling

1. Connect the FRDM-MC-LVPMSM shield on top of the MIMXRT1160-EVK or MIMXRT1170-EVK board (there is only one possible option).

NOTE

Watch out for unwanted connections between bottom of FRDM-MC-PMSM and jumpers on top of MIMXRT11xx-EVK.

2. Connect the 3-phase motor wires to the screw terminals (J7) on the Freedom PMSM power stage.
3. On the top of FRDM-MC-PMSM shield connect by wires following pins:

Table 7. MIMXRT1170-EVK pin assignment

FRDM-MC-LVPMSM	Connection	On the MIMXRT1160/1170-EVK is pin connected to
CUR_A	J2, 1 <-> J4, 2	GPIO_AD_10
CUR_B	J2, 3 <-> J4, 6	GPIO_AD_12
CUR_C	J2, 5 <-> J4, 8	GPIO_AD_13
VOLT_DCB	J2, 7 <-> J4, 4	GPIO_AD_11
CUR_DCB	J2, 9 <-> J2, 8	GPIO_AD_30

4. Plug the USB cable from the USB host to the Debug USB connector (J11) on the EVK board.
5. Plug the 24-V DC power supply to the DC power connector on the Freedom PMSM power stage.

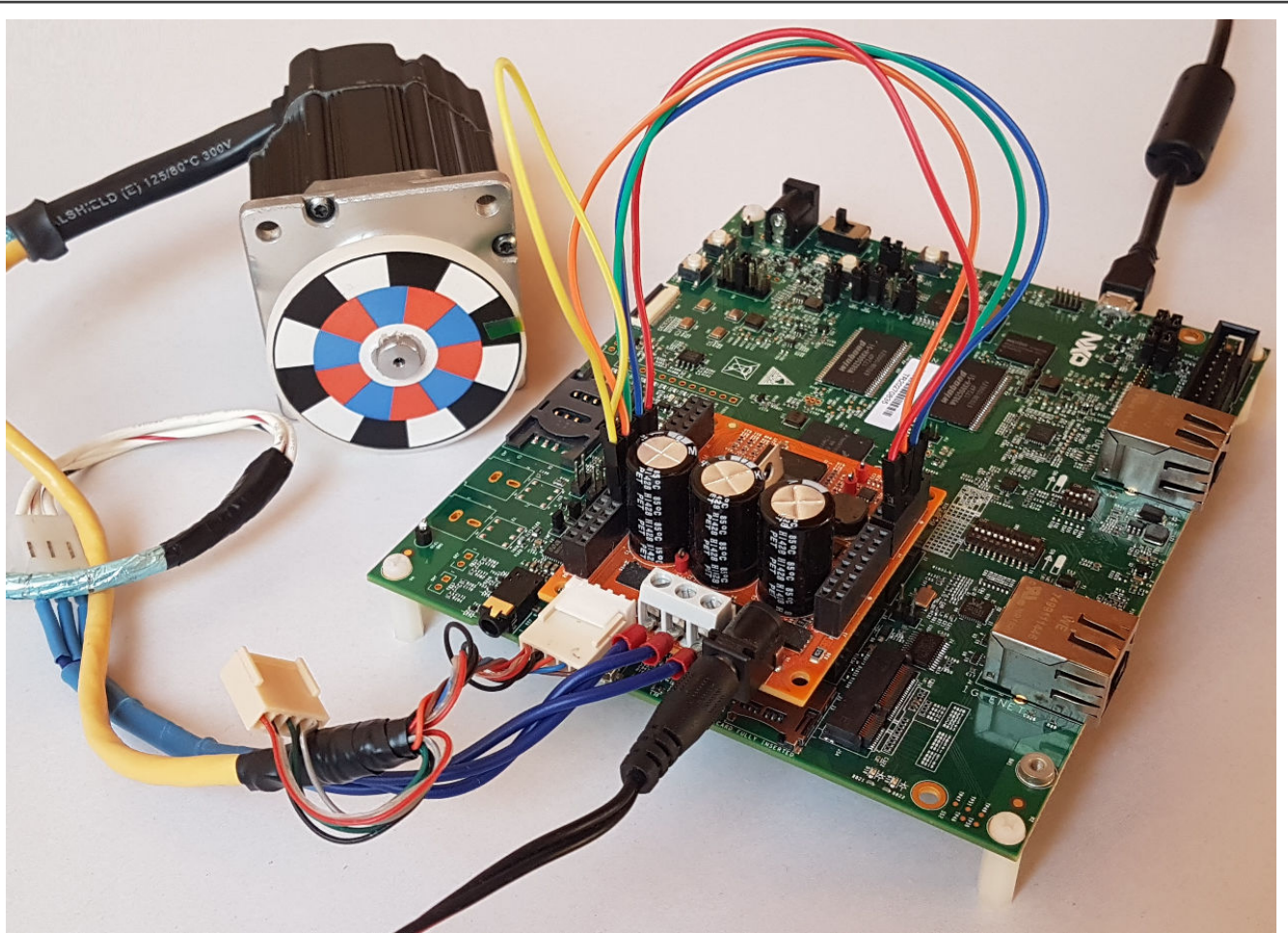

Figure 15. Assembled Freedom system

Chapter 3

RT crossover processors features and peripheral settings

This chapter describes the peripheral settings and application timing. The i.MX RT1xxx is a new processor family featuring NXP's advanced implementation of the Arm Cortex-M7 core.

3.1 i.MX RT1024

The **i.MX RT1024** is a processors of i.MX RT family featuring NXP's advanced implementation of the Arm® Cortex®-M7 core, which operates at speeds up to 500 MHz to provide high CPU performance and real-time response. The i.MX RT1024 processor has 256 KB on-chip RAM, which can be flexibly configured as TCM or general-purpose on-chip RAM. The i.MX RT1024 integrates advanced power management module with DCDC and LDO that reduces complexity of external power supply and simplifies power sequencing. The i.MX RT1024 also provides various memory interfaces, including SDRAM, RAW NAND FLASH, NOR FLASH, SD/eMMC, Quad SPI, and a wide range of connectivity interfaces including UART, SPI, I2C, USB, and CAN; for connecting peripherals including WLAN, Bluetooth™, and GPS. The i.MX RT1024 also has rich audio features, including SPDIF and I2S audio interface. Various analog IP integration, including ADC, analog comparator, temperature sensor, etc. For more information about i.MX RT1024 see *i.MX RT1024 Processor Reference Manual*. (Document [IMXRT1024RM](#))

3.1.1 RT1024 - Hardware timing and synchronization

Correct and precise timing is crucial for motor-control applications. Therefore, the motor-control-dedicated peripherals take care of the timing and synchronization on the hardware layer. In addition, you can set the PWM frequency as a multiple of the ADC interrupt (ADC ISR) frequency where the FOC algorithm is calculated. In this case, the PWM frequency is equal to the FOC frequency.

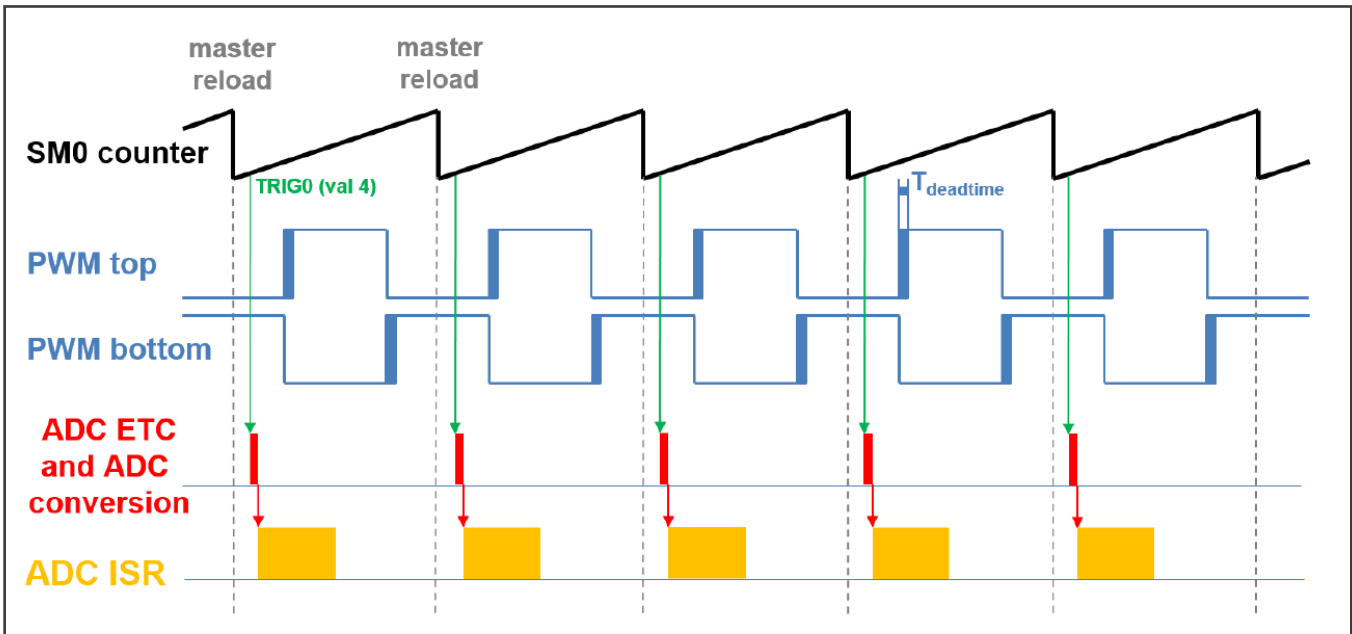

Figure 16. Hardware timing and synchronization on i.MX RT1024

- The top signal shows the eFlexPWM counter (SM0 counter). The dead time is emphasized at the PWM top and PWM bottom signals. The SM0 submodule generates the master reload at every opportunity.

- The SM0 generates trigger 0 (when the counter counts to a value equal to the TRIG4 value) for the ADC_ETC (ADC External Trigger Control) with a delay of approximately $T_{\text{deatime}}/2$. This delay ensures correct current sampling at the duty cycles close to 100 %.
- ADC_ETC starts the ADC conversion.
- When the ADC conversion is completed, the ADC ISR (ADC interrupt) is entered. The FOC calculation is done in this interrupt.

3.1.2 RT1024 - Peripheral settings

This section describes the peripherals used for the motor control. On i.MX RT1024, there are three submodules from the enhanced FlexPWM (eFlexPWM) used for 6-channel PWM generation and two 12-bit ADCs for the phase currents and DC-bus voltage measurement. The eFlexPWM and ADC are synchronized via submodule 0 from the eFlexPWM. The following settings are located in the *mc_periph_init.c* and *peripherals.c* files and their header files.

Clock Control Module (CCM)

The CCM generates and controls the clocks of various modules in the design and manages the low-power modes. This module uses the available clock sources to generate the clock roots.

The clock sources used in the motor-control application are:

- PLL6, also called System PLL, with a frequency of 500 MHz.
- PLL3, also called USB1 PLL, with a frequency of 480 MHz.

The Arm clock core works at a frequency of 500 MHz and the clock source is PLL6. For this setting, the CBCMR[PRE_PERIPH_CLK_SEL], CBCDR[PERIPH_CLK_SEL], and CBCDR[AHB_PODF] registers are set in the *clock_config.c* file. The ADC, XBAR, and PWM are clocked from the IPG_CLK_ROOT output which has a frequency of 125 MHz. The CBCDR[IPG_PODF] register must be set for this setting. The IPG_CLK_ROOT is sourced from the AHB_CLK_ROOT. The LPUART is sourced from the PLL3 at a frequency of 480 MHz divided by 6.

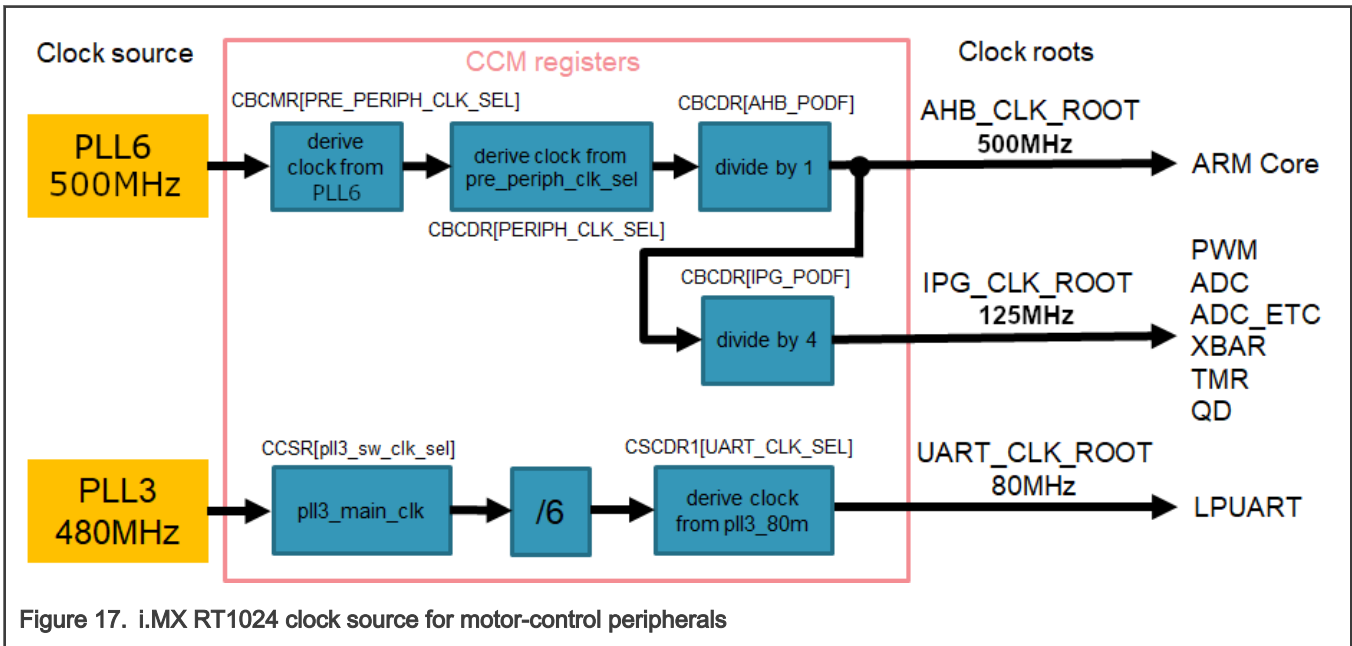

The clock sources for the peripherals used for the motor control are listed in [Table 8](#).

Table 8. i.MX RT1024 clock source for motor-control peripherals

	Clock source	Clock root	Clock root frequency
Arm core	PLL6	AHB_CLK_ROOT	500 MHz
PWM	PLL6	IPG_CLK_ROOT	125 MHz
ADCs	PLL6	IPG_CLK_ROOT	125 MHz
ADC_ETC	PLL6	IPG_CLK_ROOT	125 MHz
XBAR	PLL6	IPG_CLK_ROOT	125 MHz
TMR	PLL6	IPG_CLK_ROOT	125 MHz
QD	PLL6	IPG_CLK_ROOT	125 MHz
LPUART	PLL3	UART_CLK_ROOT	80 MHz

For more details, see the *i.MX RT1024 Processor Reference Manual* (document [IMXRT1024RM](#)).

PWM generation - PWM2

- The eFlexPWM is clocked from the 125-MHz IPG_CLK_ROOT.
- Six channels from three submodules are used for the 3-phase PWM generation. Submodule 0 generates the master reload at event every n^{th} opportunity, depending on the user-defined macro M1_FOC_FREQ_VS_PWM_FREQ.
- Submodules 1 and 3 get their clocks from submodule 0.
- The counters at submodules 1 and 3 are synchronized with the master reload signal from submodule 0 (submodule 2 is not used).
- Submodule 0 is used for synchronization with ADC_ETC. The submodule generates the output trigger after the PWM reload, when the counter counts to VAL4.
- Fault mode is enabled for channels A and B at submodules 0, 1, and 3 with automatic fault clearing (the PWM outputs are re-enabled at the first PWM reload after the fault input returns to zero).
- The PWM period (frequency) is determined by how long it takes the counter to count from INIT to VAL1. By default, INIT = $-\text{MODULO}/2 = -6250$ and VAL1 = $\text{MODULO}/2 - 1 = 6249$. The eFlexPWM clock is 125 MHz so it takes 0.0001 s (10 KHz).
- Dead-time insertion is enabled. Define the dead-time length in the M1_PWM_DEADTIME macro.

Over-current detection - CMP3

- The plus input for the CMP3 (CMP2_IN3) is taken from the analog pin.
- The minus input for the CMP3 (CMP2_IN7) is taken from the 6-bit DAC0 reference. The DAC reference is set to 3.197 V, which corresponds to 7.73 A (in the 8.25 A scale).
- The CMP filter is enabled and four consecutive samples must match.

ADC external trigger control - ADC_ETC

The ADC_ETC module enables multiple users to share the ADC modules in the Time Division Multiplexing (TDM) way. The external triggers can be brought from the Cross BAR (XBAR) or other sources. The ADC scan is started via ADC_ETC.

- Both ADCs have set their own trigger chains.
- The trigger chain length is set to 2. The back-to-back ADC trigger mode is enabled.
- The SyncMode is on. In the SyncMode, ADC1 and ADC2 are controlled by the same trigger source. The trigger source is the PWM submodule 0.

Analog sensing - ADC1 and ADC2

ADC1 and ADC2 are used for the MC analog sensing of currents and DC-bus voltage.

- The clock frequency for ADC1 and ADC2 is 62.5 MHz. It is taken from the IPG_CLK_ROOT and divided by 2.
- The ADCs operate as 10-bit with the single-ended conversion and hardware trigger selected. The ADCs are triggered from ADC_ETC by the trigger generated by the eFlexPWM.
- The conversion-complete interrupt is enabled and serves the FOC fast-loop algorithm generated after the last scan is completed by ADC1.

Quadrature Decoder (QD) module

The QD module is used to sense the position and speed from the encoder sensor.

- The direction of counting is set in the M1_POSPE_ENC_DIRECTION macro.
- The modulo counting and the modulus counting roll-over/under to increment/decrement revolution counter are enabled.

Peripheral interconnection for - XBARA1

The crossbar is used to interconnect the trigger from the PWM to the ADC_ETC and to connect the encoder (connected to GPIO) to the QD.

- The FLEXPWM2_PWM1_OUT_TRIG0_1 output trigger (generated by submodule 0) is connected to ADC_ETC_XBAR0_TRIG0.
- The encoder signal Phase A - IOMUX_XBAR_INOUT12 output is assigned to ENC1_PHASE_A_INPUT (GPIO_AD_B1_08 is configured as XBAR1_INOUT12 in *pinmux.c*).
- The encoder signal Phase B - IOMUX_XBAR_INOUT13 output is assigned to ENC1_PHASE_B_INPUT (GPIO_AD_B1_09 is configured as XBAR1_INOUT13 in *pinmux.c*).

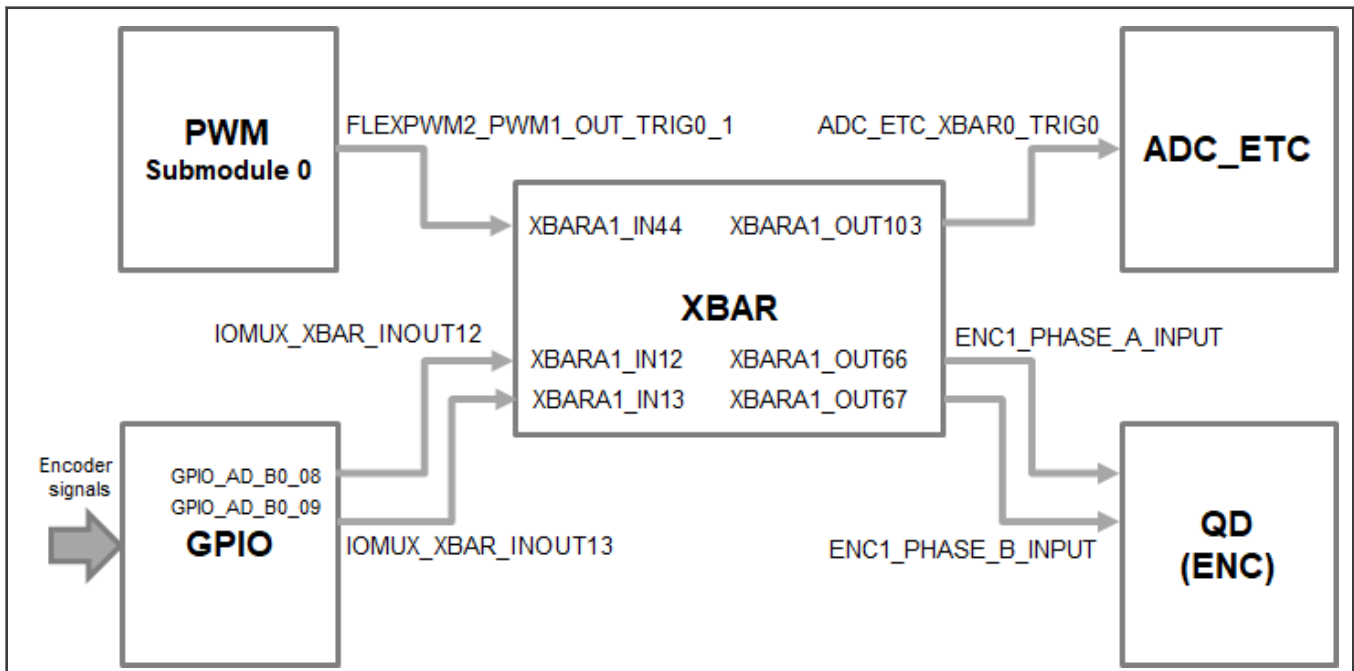

Figure 18. Crossbar interconnection for i.MX RT1024

Slow-loop interrupt generation - TMR1

The QuadTimer module TMR1 is used to generate the slow-loop interrupt.

- QuadTimer TMR1 is clocked from IPG CLK ROOT divided by 16, so the clock frequency of TMR1 is 7.8125 MHz.

- The slow loop is usually ten times slower than the fast loop. Therefore, the interrupt is generated after the counter counts from CNTR0 = 0 to COMP1 = IPG CLK ROOT / (16U * Speed Loop Freq). The speed loop frequency is set in the M1_SPEED_LOOP_FREQ macro and equals 1000 Hz.
- An interrupt (which serves the slow-loop period) is enabled and generated at the reload event.

FreeMASTER communication—LPUART0

LPUART0 (Low-Power Universal Asynchronous Receiver and Transmitter) is used for the FreeMASTER communication between the MCU board and the PC.

- The baud rate is set to 115200 bit/s.
- The receiver and transmitter are both enabled.
- The other settings are set to default.

3.2 i.MX RT106x

The MIMXRT1060-EVK, MIMXRT1060-EVKB and MIMXRT1064-EVK boards are platforms designed to showcase the features of the i.MX RT106x processors in small, low-cost packages. The MIMXRT106x-EVK/B boards are entry-level development boards, which help you to become familiar with the processors before investing a large amount of resources into more specific designs. The EVK boards provide various types of memory, especially the 64-Mbit Quad SPI flash and 512-Mbit Hyper flash.

3.2.1 RT1060/64 - Hardware timing and synchronization

Correct and precise timing is crucial for motor-control applications. Therefore, the motor-control-dedicated peripherals take care of the timing and synchronization on the hardware layer. In addition, it is possible to set the PWM frequency as a multiple of the ADC interrupt (ADC ISR) frequency where the FOC algorithm is calculated. In this case, the PWM frequency is equal to the FOC frequency.

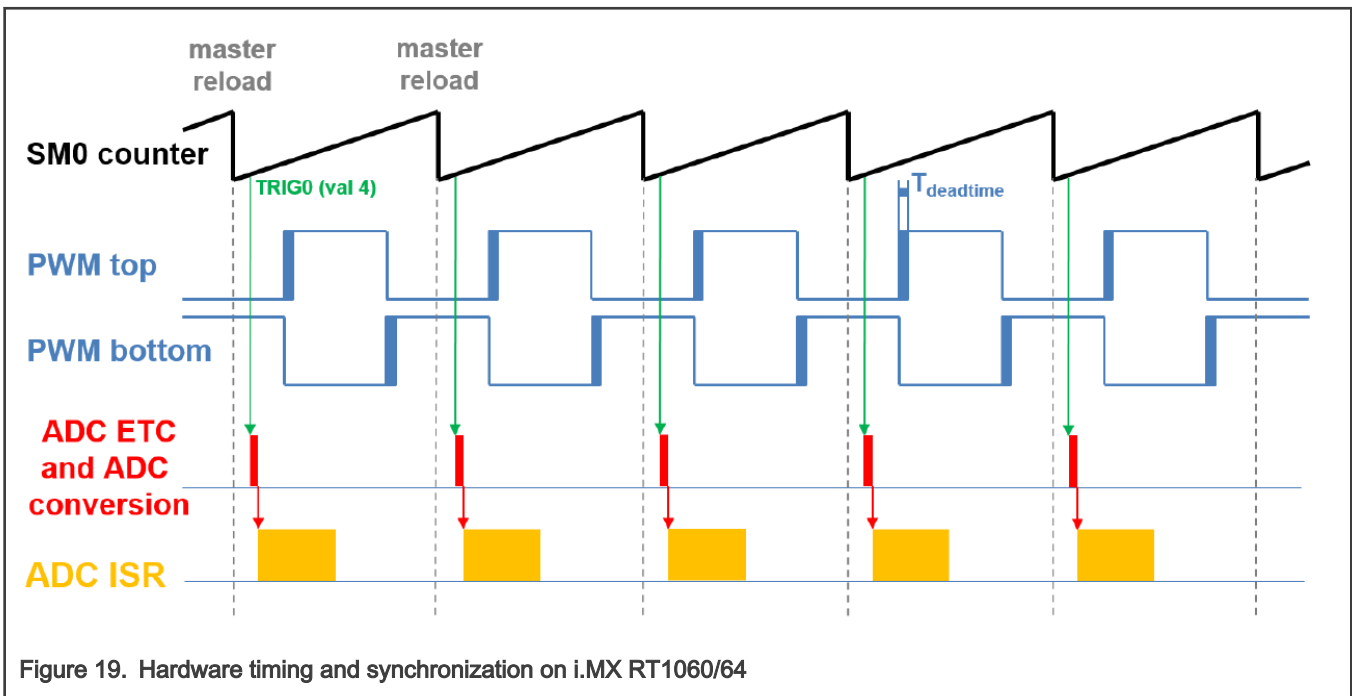

Figure 19. Hardware timing and synchronization on i.MX RT1060/64

- The top signal shows the eFlexPWM counter (SM0 counter). The dead time is emphasized at the PWM top and PWM bottom signals. The SM0 submodule generates the master reload at every opportunity.
- SM0 generates trigger 0 (when the counter counts to a value equal to the TRIG4 value) for the ADC_ETC (ADC External Trigger Control) with a delay of approximately $T_{deadtime}/2$. This delay ensures correct current sampling at duty cycles close to 100 %.

- ADC_ETC starts the ADC conversion.
- When the ADC conversion is completed, the ADC ISR (ADC interrupt) is entered. The FOC calculation is done in this interrupt.

3.2.2 RT1060/64 - Peripheral settings

This section describes the peripherals used for motor control. On i.MX RT1060/1064, there are three submodules from the enhanced FlexPWM (eFlexPWM) used for 6-channel PWM generation and two 12-bit ADCs for the phase currents and DC-bus voltage measurement. The eFlexPWM and ADC are synchronized via submodule 0 from the eFlexPWM. The following settings are located in the *mc_periph_init.c* and *peripherals.c* files and their header files.

Clock Control Module (CCM)

The CCM generates and controls the clocks of various modules in the design and manages the low-power modes. This module uses the available clock sources to generate the clock roots.

The clock sources used in the motor-control application are:

- PLL1, also called ARM PLL, with a frequency of 1.2 GHz.
- PLL3, also called USB1 PLL with a frequency of 480 MHz.

The Arm clock core works at a frequency of 600 MHz and the clock source is PLL1 divided by 2. For this setting, the CBCMR[PRE_PERIPH_CLK_SEL], CBCDR[PERIPH_CLK_SEL], and CBCDR[AHB_PODF] registers are set in the *clock_config.c* file. The ADC, XBAR, and PWM are clocked from the IPG_CLK_ROOT output which has a frequency of 150 MHz. The CBCDR[IPG_PODF] register must be set for this setting. IPG_CLK_ROOT is sourced from AHB_CLK_ROOT. LPUART is sourced from PLL3 at a frequency of 480 MHz divided by 6.

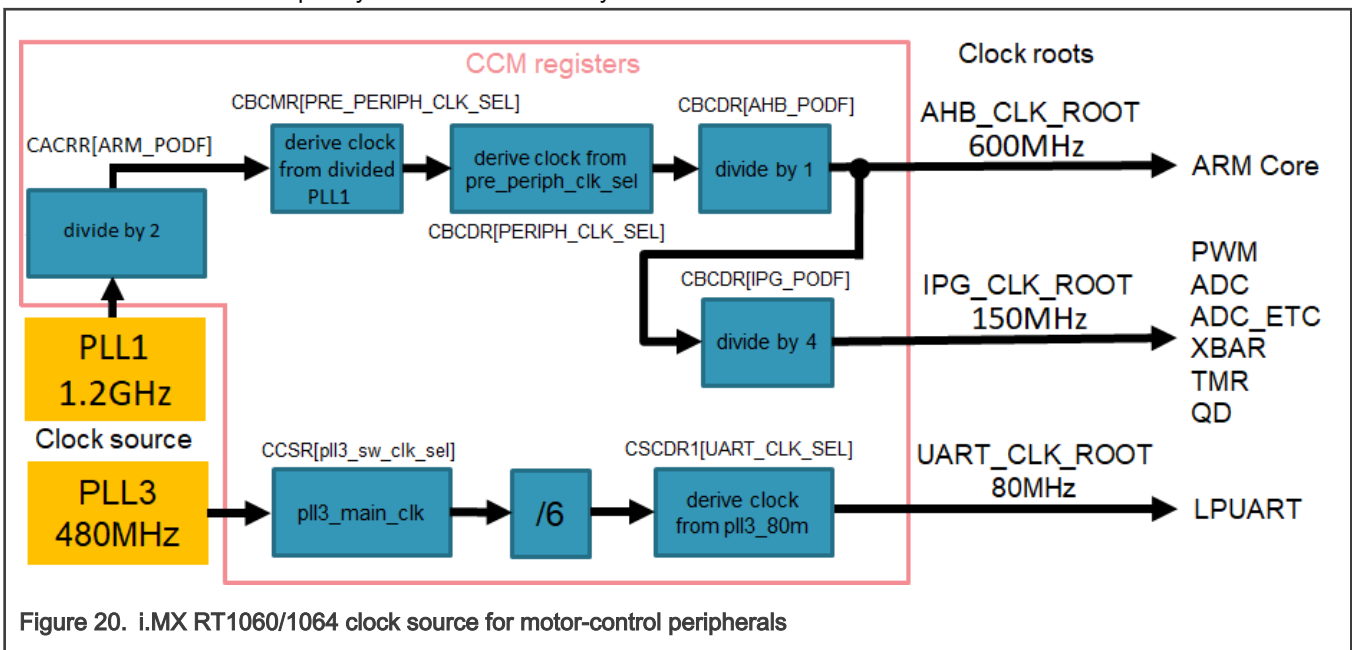

Figure 20. i.MX RT1060/1064 clock source for motor-control peripherals

The clock sources for the peripherals used for motor control are listed in Table 9.

Table 9. i.MX RT1060/1064 clock source for motor-control peripherals

	Clock source	Clock root	Clock root frequency
Arm core	PLL2	AHB_CLK_ROOT	600 MHz
PWM	PLL2	IPG_CLK_ROOT	150 MHz

Table continues on the next page...

Table 9. i.MX RT1060/1064 clock source for motor-control peripherals (continued)

	Clock source	Clock root	Clock root frequency
ADCs	PLL2	IPG_CLK_ROOT	150 MHz
ADC_ETC	PLL2	IPG_CLK_ROOT	150 MHz
XBAR	PLL2	IPG_CLK_ROOT	150 MHz
TMR	PLL2	IPG_CLK_ROOT	150 MHz
QD	PLL2	IPG_CLK_ROOT	150 MHz
LPUART	PLL3	UART_CLK_ROOT	80 MHz

For more details, see the [i.MX RT1060](#) or [i.MX RT1064](#) processor reference manuals.

PWM generation - PWM1

- The eFlexPWM is clocked from the 150-MHz IPG_CLK_ROOT.
- Six channels from three submodules are used for the 3-phase PWM generation. Submodule 0 generates the master reload at event every nth opportunity, depending on the user-defined macro M1_FOC_FREQ_VS_PWM_FREQ.
- Submodules 1 and 3 get their clocks from submodule 0.
- The counters at submodules 1 and 3 are synchronized with the master reload signal from submodule 0 (submodule 2 is not used).
- Submodule 0 is used for synchronization with ADC_ETC. The submodule generates the output trigger after the PWM reload, when the counter counts to VAL4.
- The fault mode is enabled for channels A and B at submodules 0, 1, and 3 with automatic fault clearing (the PWM outputs are re-enabled at the first PWM reload after the fault input returns to zero).
- The PWM period (frequency) is determined by how long it takes the counter to count from INIT to VAL1. By default, INIT = -MODULO/2 = -7500 and VAL1 = MODULO/2 - 1 = 7499. The eFlexPWM clock is 150 MHz so it takes 0.0001 s (10 KHz).
- Dead time insertion is enabled. The dead time length is defined by the user in the M1_PWM_DEADTIME macro.

Over-current detection - CMP2

- The plus input for the CMP2 (CMP2_IN3) is taken from the analog pin.
- The minus input for the CMP2 (CMP2_IN7) is taken from the 6-bit DAC0 reference. The DAC reference is set to 3.197 V, which corresponds to 7.73 A (in the 8.25 A scale).
- The CMP filter is enabled and four consecutive samples must match.

ADC external trigger control - ADC_ETC

The ADC_ETC module enables multiple users to share the ADC modules in the Time Division Multiplexing (TDM) way. The external triggers can be brought from the Cross BAR (XBAR) or other sources. The ADC scan is started via ADC_ETC.

- Both ADCs have set their own trigger chains.
- The trigger chain length is set to 2. The back-to-back ADC trigger mode is enabled.
- The SyncMode is on. In the SyncMode, ADC1 and ADC2 are controlled by the same trigger source. The trigger source is the PWM submodule 0.

Analog sensing - ADC1 and ADC2

ADC1 and ADC2 are used for the MC analog sensing of currents and DC-bus voltage.

- The clock frequency for ADC1 and ADC2 is 75 MHz. It is taken from IPG_CLK_ROOT and divided by 2.
- The ADCs operate as 10-bit with the single-ended conversion and hardware trigger selected. The ADCs are triggered from ADC_ETC by the trigger generated by the eFlexPWM.
- The conversion-complete interrupt is enabled and serves the FOC fast-loop algorithm generated after the last scan is completed by ADC1.

Quadrature Decoder (QD) module

The QD module is used to sense the position and speed from the encoder sensor.

- The direction of counting is set in the M1_POSPE_ENC_DIRECTION macro.
- The modulo counting and the modulus counting roll-over/under to increment/decrement revolution counter are enabled.

Peripheral interconnection for i.MX RT1060 - XBARA1

The crossbar is used to interconnect the trigger from the PWM to the ADC_ETC and to connect the encoder (connected to GPIO) to the QD.

- The FLEXPWM1_PWM1_OUT_TRIG0_1 output trigger (generated by submodule 0) is connected to ADC_ETC_XBAR0_TRIG0.
- The encoder signal Phase A - IOMUX_XBAR_INOUT16 output is assigned to ENC1_PHASE_A_INPUT (GPIO_AD_B0_02 is configured as XBAR1_INOUT16 in the *pinmux.c* file).
- The encoder signal Phase B - IOMUX_XBAR_INOUT17 output is assigned to ENC1_PHASE_B_INPUT (GPIO_AD_B0_03 is configured as XBAR1_INOUT17 in the *pinmux.c* file).

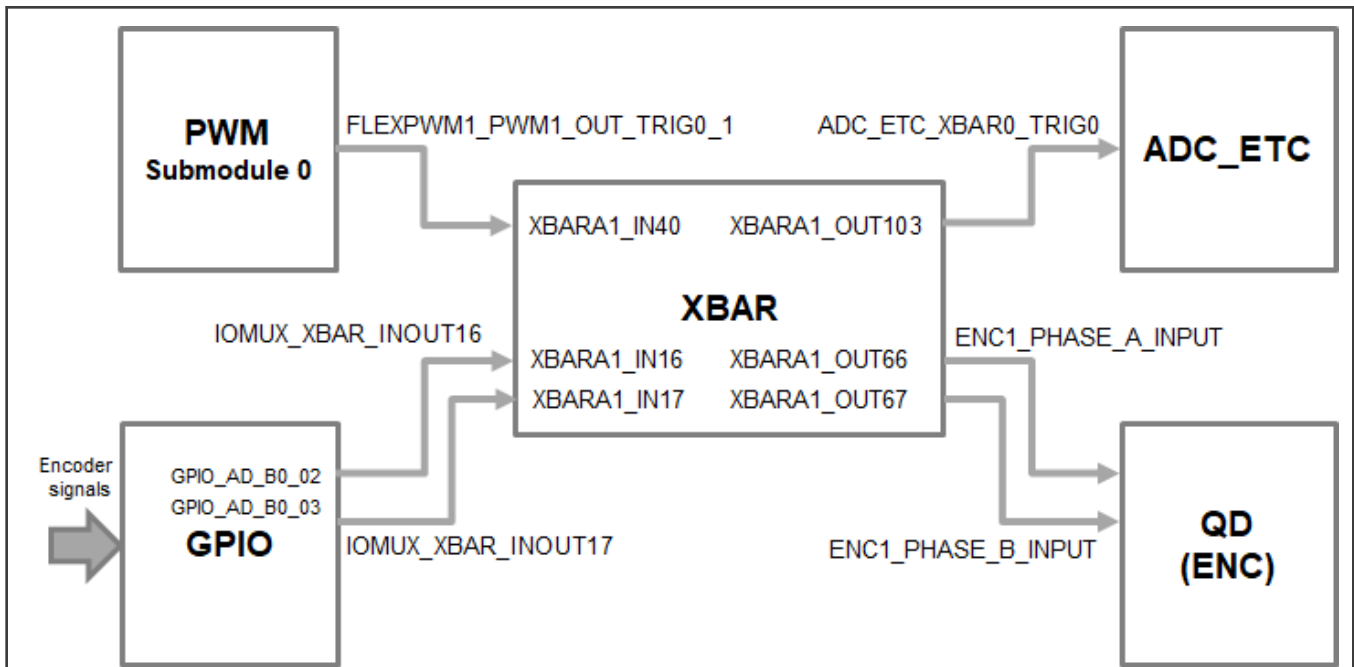

Figure 21. Crossbar interconnection for i.MX RT1060

Slow-loop interrupt generation - TMR1

The QuadTimer module TMR1 is used to generate the slow-loop interrupt.

- QuadTimer TMR1 is clocked from IPG CLK ROOT divided by 16, so the clock frequency of TMR1 is 9.375 MHz.
- The slow loop is usually ten times slower than the fast loop. Therefore, the interrupt is generated after the counter counts from CNTR0 = 0 to COMP1 = IPG CLK ROOT / (16U * Speed Loop Freq). The speed-loop frequency is set in the M1_SPEED_LOOP_FREQ macro and equals 1000 Hz.

- An interrupt (which serves the slow-loop period) is enabled and generated at the reload event.

FreeMASTER communication—LPUART0

LPUART0 (Low-Power Universal Asynchronous Receiver and Transmitter) is used for the FreeMASTER communication between the MCU board and the PC.

- The baud rate is set to 115200 bit/s.
- The receiver and transmitter are both enabled.
- The other settings are set to default.

3.3 i.MX RT1160/1170

The **i.MX RT1160/1170** crossover MCUs are setting speed records at 1 GHz. This ground-breaking family combines superior computing power and multiple media capabilities with ease of use and real-time functionality. The i.MX RT1160/1170 MCU offers support over a wide temperature range and is qualified for consumer, industrial and automotive markets.

For more information see [i.MX RT1160](#) or [i.MX RT1170](#) Crossover MCU Family web pages.

3.3.1 RT1160/1170 - Hardware timing and synchronization

Correct and precise timing is crucial for motor-control applications. Therefore, the motor-control-dedicated peripherals take care of the timing and synchronization on the hardware layer. In addition, you can set the PWM frequency as a multiple of the ADC interrupt (ADC ISR) frequency where the FOC algorithm is calculated. In this case, the PWM frequency is equal to the FOC frequency.

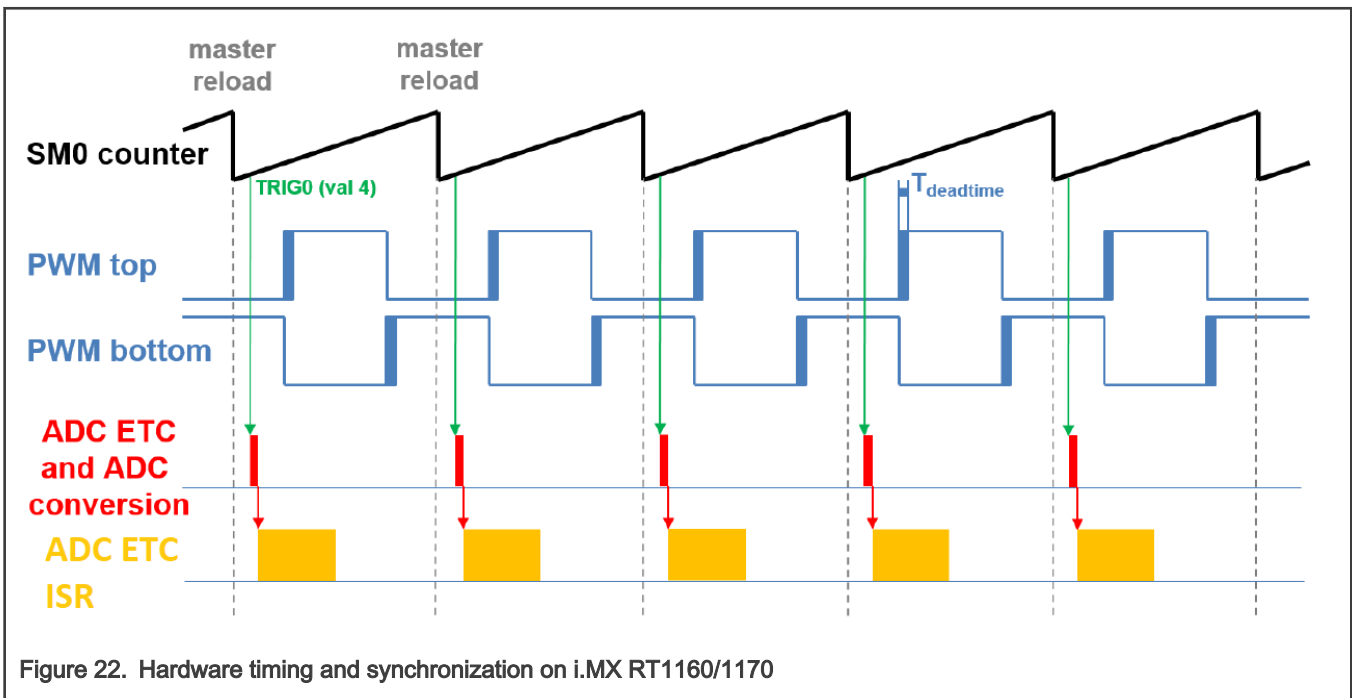

Figure 22. Hardware timing and synchronization on i.MX RT1160/1170

- The top signal shows the eFlexPWM counter (SM0 counter). The dead time is emphasized at the PWM top and PWM bottom signals. The SM0 submodule generates the master reload at every opportunity.
- The SM0 generates trigger 0 (when the counter counts to a value equal to the TRIG4 value) for the ADC_ETC (ADC External Trigger Control) with a delay of approximately $T_{deadtime}/2$. This delay ensures correct current sampling at the duty cycles close to 100 %.
- ADC_ETC starts the ADC conversion.

- When the ADC conversion is completed, the ADC_ETC ISR (ADC_ETC interrupt) is entered. The FOC calculation is done in this interrupt.

3.3.2 RT1160/1170 - Peripheral settings

This section describes the peripherals used for the motor control. On i.MX RT1160/1070, there are three submodules from the enhanced FlexPWM (eFlexPWM) used for 6-channel PWM generation and two 12-bit ADCs for the phase currents and DC-bus voltage measurement. The eFlexPWM and ADC are synchronized via submodule 0 from the eFlexPWM. The following settings are located in the *mc_periph_init.c* and *peripherals.c* files and their header files.

PWM generation - PWM1

- Six channels from three submodules are used for the 3-phase PWM generation. Submodule 0 generates the master reload at event every n^{th} opportunity, depending on the user-defined macro `M1_FOC_FREQ_VS_PWM_FREQ`.
- Submodules 1 and 2 get their clocks from submodule 0.
- The counters at submodules 1 and 2 are synchronized with the master reload signal from submodule 0.
- Submodule 0 is used for synchronization with ADC_ETC. The submodule generates the output trigger after the PWM reload, when the counter counts to VAL4.
- Fault mode is enabled for channels A and B at submodules 0, 1, and 2 with automatic fault clearing (the PWM outputs are re-enabled at the first PWM reload after the fault input returns to zero).
- The PWM period (frequency) is determined by how long it takes the counter to count from INIT to VAL1. By default, $\text{INIT} = -\text{MODULO}/2 = -12000$ and $\text{VAL1} = \text{MODULO}/2 - 1 = 11999$. The eFlexPWM clock is 240 MHz so it takes 0.0001 s (10 KHz).
- Dead-time insertion is enabled. Define the dead-time length in the `M1_PWM_DEADTIME` macro.

ADC external trigger control - ADC_ETC

The ADC_ETC module enables multiple users to share the ADC modules in the Time Division Multiplexing (TDM) way. The external triggers can be brought from the Cross BAR (XBAR) or other sources. The ADC scan is started via ADC_ETC.

- Both ADCs have set their own trigger chains.
- The trigger chain length is set to 2. The back-to-back ADC trigger mode is enabled.
- The SyncMode is on. In the SyncMode, ADC1 and ADC2 are controlled by the same trigger source. The trigger source is the PWM submodule 0.
- After both ADCs conversion is completed, ADC_ETC interrupt is enabled and serves the FOC fast-loop algorithm.

Analog sensing - ADC1 and ADC2

ADC1 and ADC2 are used for the MC analog sensing of currents and DC-bus voltage.

- The ADCs operate as 12-bit with the single-ended conversion and hardware trigger selected. The ADCs are triggered from ADC_ETC by the trigger generated by the eFlexPWM.

Quadrature Decoder (QD) module

The QD module is used to sense the position and speed from the encoder sensor.

- The direction of counting is set in the `M1_POSPE_ENC_DIRECTION` macro.
- The modulo counting and the modulus counting roll-over/under to increment/decrement revolution counter are enabled.

Peripheral interconnection for - XBARA1

The crossbar is used to interconnect the trigger from the PWM to the ADC_ETC and to connect the encoder (connected to GPIO) to the QD.

- The FLEXPWM2_PWM1_OUT_TRIG0_1 output trigger (generated by submodule 0) is connected to ADC_ETC_XBAR0_TRIG0.
- The encoder signal Phase A and Phase B are configured in *pinmux.c*.

Slow-loop interrupt generation - TMR1

The QuadTimer module TMR1 is used to generate the slow-loop interrupt.

- The slow loop is usually ten times slower than the fast loop. Therefore, the interrupt is generated after the counter counts from CNTR0 = 0 to COMP1 = IPG CLK ROOT / (16U * Speed Loop Freq). The speed loop frequency is set in the M1_SPEED_LOOP_FREQ macro and equals 1000 Hz.
- An interrupt (which serves the slow-loop period) is enabled and generated at the reload event.

FreeMASTER communication—LPUART1

LPUART1 (Low-Power Universal Asynchronous Receiver and Transmitter) is used for the FreeMASTER communication between the MCU board and the PC.

- The baud rate is set to 115200 bit/s.
- The receiver and transmitter are both enabled.
- The other settings are set to default.

3.4 RT family - CPU load and memory usage

The following information apply to the application built using the MCUXpresso IDE in the debug and release configurations. The tables below show the memory usage and CPU load. The memory usage is calculated from the *.map* linker file, including the 4-KB FreeMASTER recorder buffer allocated in RAM. The CPU load is measured using the SysTick timer. The CPU load is dependent on the fast-loop (FOC calculation) and slow-loop (speed loop) frequencies. In this case, it applies to the fast-loop frequency of 10 KHz and the slow-loop frequency of 1 KHz. The total CPU load is calculated using the following equations:

$$CPU_{fast} = \text{cycles}_{fast} \frac{f_{fast}}{f_{CPU}} 100 [\%]$$

$$CPU_{slow} = \text{cycles}_{slow} \frac{f_{slow}}{f_{CPU}} 100 [\%]$$

$$CPU_{total} = CPU_{fast} + CPU_{slow} [\%]$$

Where:

CPU_{fast} - the CPU load taken by the fast loop.

cycles_{fast} - the number of cycles consumed by the fast loop.

f_{fast} - the frequency of the fast-loop calculation (10 KHz).

f_{CPU} - CPU frequency.

CPU_{slow} - the CPU load taken by the slow loop.

cycles_{slow} - the number of cycles consumed by the slow loop.

f_{slow} - the frequency of the slow-loop calculation (1 KHz).

CPU_{total} - the total CPU load consumed by the motor control.

Table 10. i.MX RT1024 CPU load and memory usage

	debug configuration		release configuration	
Program FLASH	88 144 B	Usage 2.10%	52 380 B	1.25%
Board SRAM	-	-	-	-
SRAM_DTC	17 684 B	Usage 26.93%	17 684 B	26.93%
SRAM_ITC	-	-	-	-
SRAM_OC	-	-	-	-
	Speed Control	Position Control	Speed Control	Position Control
Maximum CPU load	7.90%	7.73%	7.70%	7.23%

Table 11. i.MX RT1060 CPU load and memory usage (similar for RT1064)

	debug configuration		release configuration	
Board FLASH	-	-	49 028 B	Usage 0.58%
Board SRAM	-	-	-	-
SRAM_DTC	8 kB	Usage 6.25%	23 060 B	Usage 17.59%
SRAM_ITC	-	-	9 672 B	Usage 7.38%
SRAM_OC	83 484 B	Usage 10.62%	-	-
	Speed Control	Position Control	Speed Control	Position Control
Maximum CPU load	7.31%	7.84%	7.25%	6.84%

Table 12. i.MX RT1170 CPU load and memory usage (similar for RT1160)

	debug configuration		release configuration	
Board FLASH	-	-	-	-
Board SRAM	-	-	-	-
SRAM_DTC	-	-	-	-
SRAM_ITC	-	-	-	-
SRAM_OC	-	-	-	-
	Speed Control	Position Control	Speed Control	Position Control
Maximum CPU load	-	-	-	-

NOTE

The maximum CPU load is depending on executing functions from RAM or FLASH memory. Executing functions can be speeding up in RTCESL_cfg.h header file by using macros RAM_OPTIM_HIGH, RAM_OPTIM_MEDIUM or RAM_OPTIM_LOW.

NOTE

Memory usage and maximum CPU load can differ depending on the used IDEs and settings.

Chapter 4

Project file and IDE workspace structure

All the necessary files are included in one package, which simplifies the distribution and decreases the size of the final package. The directory structure of this package is simple, easy to use, and organized in a logical manner. The folder structure used in the IDE is different from the structure of the PMSM package installation, but it uses the same files. The different organization is chosen due to a better manipulation with folders and files in workplaces and due to the possibility to add or remove files and directories. The “*pack_motor_board*” project includes all the available functions and routines, MID functions, scalar and vector control of the motor, FOC control, and FreeMASTER MCAT project. This project serves for development and testing purposes.

4.1 PMSM project structure

The directory tree of the PMSM project is shown in below.

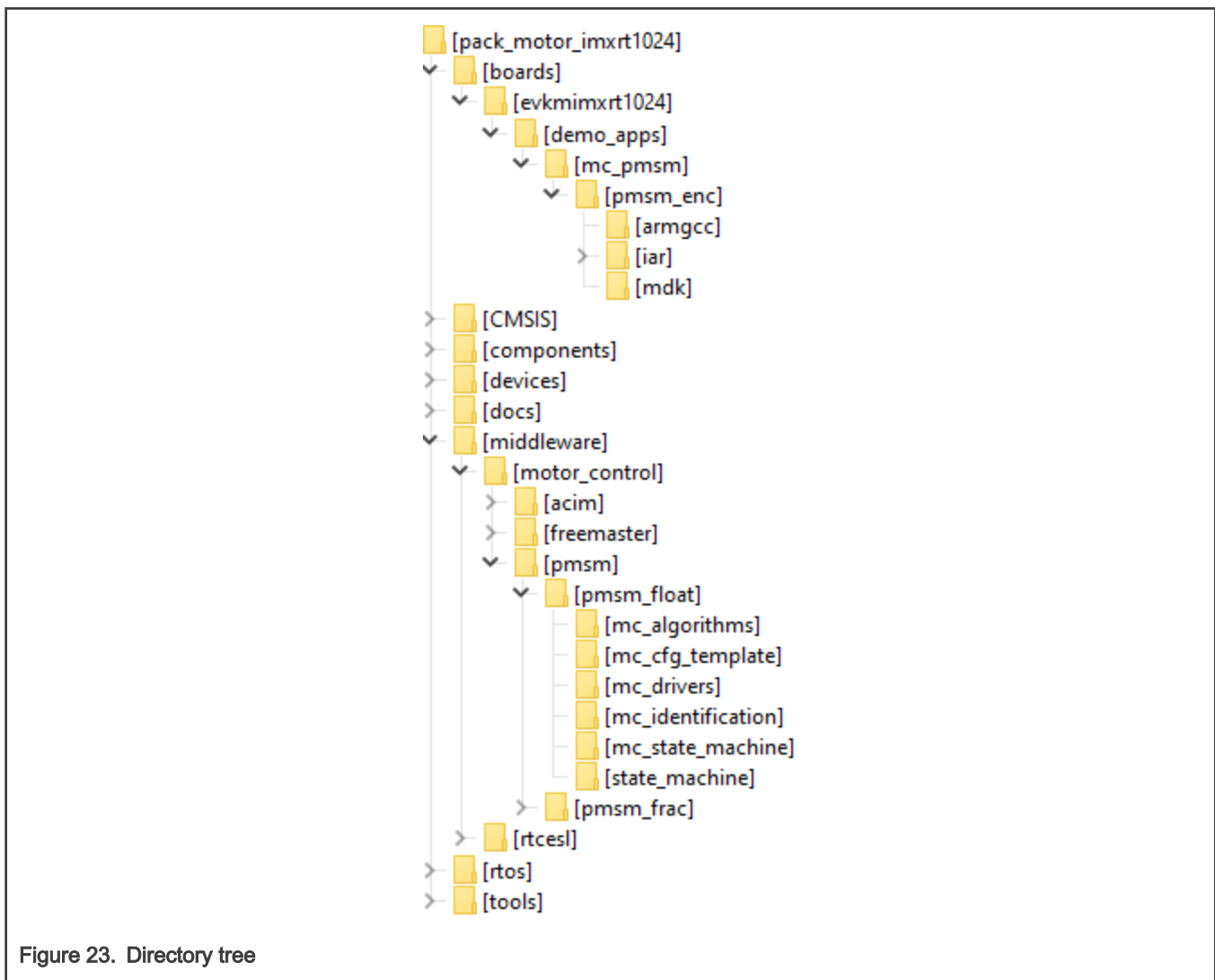

Figure 23. Directory tree

The main project folder *pack_motor_imxrt1xxx\boards\evkbimxrt1xxx\demo_apps\mc_pmsm\pmsm_enc* contains these folders and files:

- *iar*—for the IAR Embedded Workbench IDE.
- *armgcc*—for the GNU Arm IDE.

- *mdk*—for the uVision Keil IDE.
- *m1_pmsm_appconfig.h*—contains the definitions of constants for the application control processes, parameters of the motor and regulators, and the constants for other vector-control-related algorithms. When you tailor the application for a different motor using the Motor Control Application Tuning (MCAT) tool, the tool generates this file at the end of the tuning process.
- *main.c*—contains the basic application initialization (enabling interrupts), subroutines for accessing the MCU peripherals, and interrupt service routines. The FreeMASTER communication is performed in the background infinite loop.
- *board.c*—contains the functions for the UART, GPIO, and SysTick initialization.
- *board.h*—contains the definitions of the board LEDs, buttons, UART instance used for FreeMASTER, and so on.
- *clock_config.c and .h*—contains the CPU clock setup functions. These files are going to be generated by the clock tool in the future.
- *mc_periph_init.c*—contains the motor-control driver peripherals initialization functions that are specific for the board and MCU used.
- *mc_periph_init.h*—header file for *mcdrv_evkbimxrt1xxx.c*. This file contains the macros for changing the PWM period and the ADC channels assigned to the phase currents and board voltage.
- *freemaster_cfg.h*—the FreeMASTER configuration file containing the FreeMASTER communication and features setup.
- *pin_mux and .h*—port configuration files. It is recommended to generate these files in the pin tool.

The main motor-control folder *pack_motor_imxrt10xx\middleware\motor_control* contains these subfolders:

- *pmsm*—contains main PMSM motor-control functions
- *freemaster*—contains the FreeMASTER project file *pmsm_float_enc.pmp*. Open this file in the FreeMASTER tool and use it to control the application. The folder also contains the auxiliary files for the MCAT tool.

The *pack_motor_imxrt1xxx\middleware\motor_control\pmsm\pmsm_float* folder contains these subfolders common to the other motor-control projects:

- *mc_algorithms*—contains the main control algorithms used to control the FOC and speed control loop.
- *mc_drivers*—contains the source and header files used to initialize and run motor-control applications.
- *mc_identification*—contains the source code for the automated parameter-identification routines of the motor.
- *mc_state_machine*—contains the software routines that are executed when the application is in a particular state or state transition.
- *state_machine*—contains the state machine functions for the FAULT, INITIALIZATION, STOP, and RUN states.

Chapter 5

Tools

Install the [FreeMASTER Run-Time Debugging Tool 3.0](#) and one of the following IDEs on your PC to run and control the PMSM application properly:

- [IAR Embedded Workbench IDE v9.10.2](#) or higher
- [MCUXpresso v11.4.0](#)
- [ARM-MDK - Keil µVision version 5.34](#)

For `pin_mux.c`, `clock_config.c` or `peripherals.c` modifications is recommended use [MCUXpresso Configuration Tool v11](#) or higher.

NOTE

For information on how to build and run the application in your IDE, see the *Getting Started with MCUXpresso SDK* document located in the `pack_motor_<board>/docs` folder or find the related documentation at [MCUXpresso SDK builder](#).

5.1 Compiler warnings

Warnings are diagnostic messages that report constructions that are not inherently erroneous and warn about potential runtime, logic, and performance errors. In some cases, warnings can be suspended and these warnings do not show during the compiling process. One of such special cases is the “unused function” warning, where the function is implemented in the source code with its body, but this function is not used. This case occurs when you implement the function as a supporting function for better usability, but you do not use the function for any special purposes for a while.

The IAR Embedded Workbench IDE suppresses these warnings:

- Pa082 - undefined behavior; the order of volatile accesses is not defined in this statement.
- Pa050 - non-native end of line sequence detected.

The Arm-MDK Keil µVision IDE suppresses these warnings:

- 6314 - No section matches pattern xxx.o (yy).

By default, there are no other warnings shown during the compiling process.

Chapter 6

Motor-control peripheral initialization

The motor-control peripherals are initialized by calling the `MCDRV_Init_M1()` function during MCU startup and before the peripherals are used. All initialization functions are in the `mc_periph_init.c` source file and the `mc_periph_init.h` header file. The definitions specified by the user are also in these files. The features provided by the functions are the 3-phase PWM generation and 3-phase current measurement, as well as the DC-bus voltage and auxiliary quantity measurement. The principles of both the 3-phase current measurement and the PWM generation using the Space Vector Modulation (SVM) technique are described in *Sensorless PMSM Field-Oriented Control* (document [DRM148](#)).

The `mc_periph_init.h` header file provides several macros, which can be defined by the user:

- `M1_MCDRV_ADC_PERIPH_INIT`—this macro calls ADC peripheral initialization.
- `M1_MCDRV_PWM_PERIPH_INIT`—this macro calls PWM peripheral initialization.
- `M1_MCDRV_QD_ENC`—this macro calls QD peripheral initialization.
- `M1_PWM_FREQ`—the value of this definition sets the PWM frequency.
- `M1_FOC_FREQ_VS_PWM_FREQ`—enables you to call the fast-loop interrupt at every first, second, third, or n^{th} PWM reload. This is convenient when the PWM frequency must be higher than the maximal fast-loop interrupt.
- `M1_SPEED_LOOP_FREQ`—the value of this definition sets the speed loop frequency (TMR1 interrupt).
- `M1_PWM_DEADTIME`—the value of the PWM dead time in nanoseconds.
- `M1_PWM_PAIR_PH[A..C]`—these macros enable a simple assignment of the physical motor phases to the PWM periphery channels (or submodules). You can change the order of the motor phases this way.
- `M1_ADC[1,2]_PH[A..C]`—these macros are used to assign the ADC channels for the phase current measurement. The general rule is that at least one phase current must be measurable on both ADC converters and the two remaining phase currents must be measurable on different ADC converters. The reason for this is that the selection of the phase current pair to measure depends on the current SVM sector. If this rule is broken, a preprocessor error is issued. For more information about the 3-phase current measurement, see *Sensorless PMSM Field-Oriented Control* (document [DRM148](#)).
- `M1_ADC[1,2]_UDCB`—this define is used to select the ADC channel for the measurement of the DC-bus voltage.

In the motor-control software, these API-serving ADC and PWM peripherals are available:

- The available APIs for the ADC are:
 - `mcdrv_adc_t`—MCDRV ADC structure data type.
 - `bool_t M1_MCDRV_ADC_PERIPH_INIT()`—this function is by default called during the ADC peripheral initialization procedure invoked by the `MCDRV_Init_M1()` function and should not be called again after the peripheral initialization is done.
 - `bool_t M1_MCDRV_CURR_3PH_CHAN_ASSIGN(mcdrv_adc_t*)`—calling this function assigns proper ADC channels for the next 3-phase current measurement based on the SVM sector. The function always returns true.
 - `bool_t M1_MCDRV_CURR_3PH_CALIB_INIT(mcdrv_adc_t*)`—this function initializes the phase-current channel-offset measurement. This function always returns true.
 - `bool_t M1_MCDRV_CURR_3PH_CALIB(mcdrv_adc_t*)`—this function reads the current information from the unpowered phases of a stand-still motor and filters them using moving average filters. The goal is to obtain the value of the measurement offset. The length of the window for moving the average filters is set to eight samples by default. This function always returns true.
 - `bool_t M1_MCDRV_CURR_3PH_CALIB_SET(mcdrv_adc_t*)`—this function asserts the phase-current measurement offset values to the internal registers. Call this function after a sufficient number of `M1_MCDRV_CURR_3PH_CALIB()` calls. This function always returns true.

- `bool_t M1_MCDRV_ADC_GET(mcdrv_adc_t*)`—this function reads and calculates the actual values of the 3-phase currents, DC-bus voltage, and auxiliary quantity. This function always returns true.
- The available APIs for the PWM are:
 - `mcdrv_pwm3ph_t`—MCDRV PWM structure data type.
 - `bool_t M1_MCDRV_PWM_PERIPH_INIT`—this function is by default called during the PWM periphery initialization procedure invoked by the `MCDRV_Init_M1()` function.
 - `bool_t M1_MCDRV_PWM3PH_SET(mcdrv_pwm3ph_t*)`—this function updates the PWM phase duty cycles. This function always returns true.
 - `bool_t M1_MCDRV_PWM3PH_EN(mcdrv_pwm3ph_t*)`—this function enables all PWM channels. This function always returns true.
 - `bool_t M1_MCDRV_PWM3PH_DIS (mcdrv_pwm3ph_t*)`—this function disables all PWM channels. This function always returns true.
 - `bool_t M1_MCDRV_PWM3PH_FLT_GET(mcdrv_pwm3ph_t*)`—this function returns the state of the over-current fault flags and automatically clears the flags (if set). This function returns true when an over-current event occurs. Otherwise, it returns false.
- The available APIs for the quadrature encoder are:
 - `mcdrv_qd_enc_t`—MCDRV QD structure data type.
 - `bool_t M1_MCDRV_QD_PERIPH_INIT()`—this function is by default called during the QD periphery initialization procedure invoked by the `MCDRV_Init_M1()` function.
 - `bool_t M1_MCDRV_QD_GET(mcdrv_qd_enc_t*)`—this function returns the actual position and speed. This function always returns true.
 - `bool_t M1_MCDRV_QD_SET_DIRECTION(mcdrv_qd_enc_t*)`—this function sets the direction of the quadrature encoder. This function always returns true.
 - `bool_t M1_MCDRV_QD_CLEAR(mcdrv_qd_enc_t*)`—this function clears the internal variables and decoder counter. This function always returns true.

Chapter 7

User interface

The application contains the demo mode to demonstrate motor rotation. You can operate it either using the user button, or using FreeMASTER. The NXP EVK boards include a user button associated with a port interrupt (generated whenever one of the buttons is pressed). At the beginning of the ISR, a simple logic executes and the interrupt flag clears. When you press the button, the demo mode starts. When you press the same button again, the application stops and transitions back to the STOP state.

The other way to interact with the demo mode is to use the FreeMASTER tool. The FreeMASTER application consists of two parts: the PC application used for variable visualization and the set of software drivers running in the embedded application. Data is transferred between the PC and the embedded application via the serial interface. This interface is provided by the CMSIS-DAP debugger included in the boards.

The application can be controlled using these two interfaces:

- The button on the MIMXRT1xxx-EVK development board (controlling the demo mode):
 - MIMXRT1024-EVK - SW4
 - MIMXRT1060-EVK - SW8
 - MIMXRT1060-EVKB - SW8
 - MIMXRT1064-EVK - SW8
 - MIMXRT1160-EVK - SW7
 - MIMXRT1170-EVK - SW7
- Remote control using FreeMASTER (chapter [Remote control using FreeMASTER](#)):
 - Using the Motor Control Application Tuning (MCAT) interface in the “Control Structure” tab or the “Application control” tab (controlling the demo mode).
 - Setting a variable in the FreeMASTER Variable Watch.

If you are using your own motor (different from the default motors), make sure to identify all motor parameters. The automated parameter identification is described in the following sections.

Chapter 8

Remote control using FreeMASTER

This section provides information about the tools and recommended procedures to control the sensor/sensorless PMSM Field-Oriented Control (FOC) application using FreeMASTER. The application contains the embedded-side driver of the FreeMASTER real-time debug monitor and data visualization tool for communication with the PC. It supports non-intrusive monitoring, as well as the modification of target variables in real time, which is very useful for the algorithm tuning. Besides the target-side driver, the FreeMASTER tool requires the installation of the PC application as well. You can download FreeMASTER 3.0 at www.nxp.com/freemaster. To run the FreeMASTER application including the MCAT tool, double-click the *pmsm_float_enc.pmp* file located in the *pack_motor_imxrt1xxx\middleware\motor_control\freemaster* folder. The FreeMASTER application starts and the environment is created automatically, as defined in the *.pmp file.

NOTE

In MCUXpresso can be FreeMASTER application run directly from IDE in *motor_control/freemaster* folder

8.1 Establishing FreeMASTER communication

The remote operation is provided by FreeMASTER via the USB interface. Perform the following steps to control a PMSM motor using FreeMASTER:

1. Download the project from your chosen IDE to the MCU and run it.
2. Open the FreeMASTER file *pmsm_x.pmp*. The PMSM project uses the TSA by default, so it is not necessary to select a symbol file for FreeMASTER.
3. Click the communication button (the red “STOP” button in the top left-hand corner) to establish the communication.

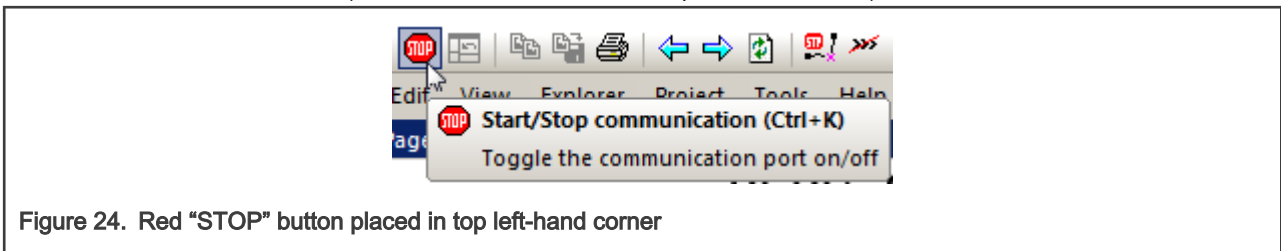

Figure 24. Red “STOP” button placed in top left-hand corner

4. If the communication is established successfully, the FreeMASTER communication status in the bottom right-hand corner changes from “Not connected” to “RS232 UART Communication; COMxx; speed=115200”. Otherwise, the FreeMASTER warning popup window appears.



Figure 25. FreeMASTER—communication is established successfully

5. Press *F5* to reload the MCAT HTML page and check the App ID.
6. Control the PMSM motor using the MCAT “Control structure” tab, the MCAT “Application demo control” tab, or by directly writing to a variable in a variable watch.
7. If you rebuild and download the new code to the target, turn the FreeMASTER application off and on.

If the communication is not established successfully, perform the following steps:

1. Go to the “Project -> Options -> Comm” tab and make sure that the correct COM port is selected and the communication speed is set to 115200 bps.

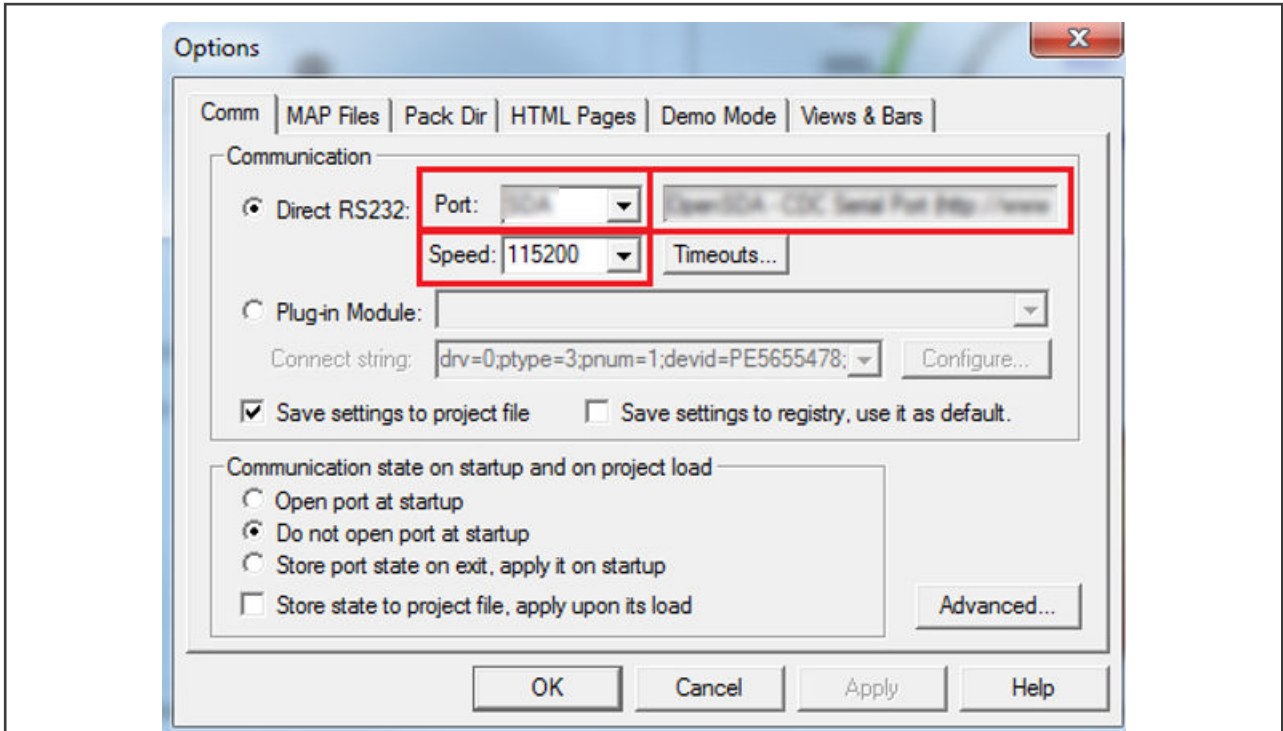

Figure 26. FreeMASTER communication setup window

2. If “OpenSDA-CDC Serial Port” is not printed out in the message box next to the “Port” drop-down menu, unplug and then plug in the USB cable and reopen the FreeMASTER project.

Make sure to supply your development board from a sufficient energy source. Sometimes the PC USB port is not sufficient to supply the development board.

8.2 MCAT FreeMASTER interface (Motor Control Application Tuning)

The PMSM sensor/sensorless FOC application can be easily controlled and tuned using the Motor Control Application Tuning (MCAT) plug-in for PMSM. The MCAT for PMSM is a user-friendly modular page, which runs within FreeMASTER. The tool consists of the tab menu, tuning mode selector, and workspace shown in Figure 27. Each tab from the tab menu represents one sub-module which enables you to tune or control different aspects of the application. Besides the MCAT page for PMSM, several scopes, recorders, and variables in the project tree are predefined in the FreeMASTER project file to further simplify the motor parameter tuning and debugging. When the FreeMASTER is not connected to the target, the “App ID” line shows “offline”. When the communication with the target MCU is established using a correct software, the “App ID” line displays the board name “pmsm_used_board” and all stored parameters for the given MCU are loaded. If the connection is established and the board ID is not shown, press *F5* to reload the MCAT HTML page.

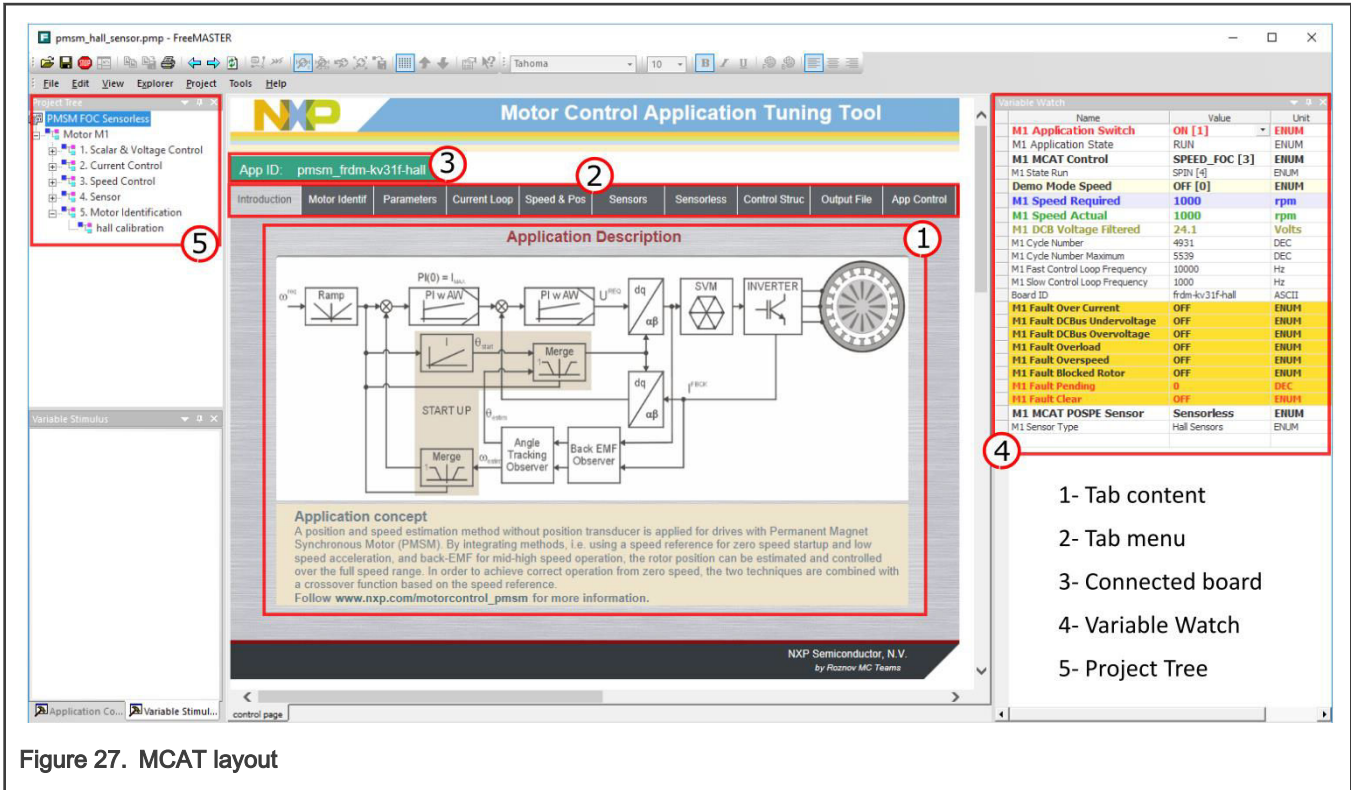

Figure 27. MCAT layout

In the default configuration, the following tabs are available:

- “Introduction”—welcome page with the PMSM sensor/sensorless FOC diagram and a short description of the application.
- “Motor Identif”—PMSM semi-automated parameter measurement control page. The PMSM parameter identification is more closely described further on in this document.
- “Parameters”—this page enables you to modify the motor parameters, specification of hardware and application scales, alignment, and fault limits.
- “Current Loop”—current loop PI controller gains and output limits.
- “Speed & Pos”—this tab contains fields for the specification of the speed controller proportional and integral gains, as well as the output limits and parameters of the speed ramp. The position proportional controller constant is also set here.
- “Sensors”—this page contains the encoder parameters and position observer parameters.
- “Sensorless”—this page enables you to tune the parameters of the BEMF observer, tracking observer, and open-loop startup.
- “Control Struc”—this application control page enables you to select and control the PMSM using different techniques (scalar—Volt/Hertz control, voltage FOC, current FOC, speed FOC, and position FOC). The application state is also shown in this tab.
- “Output file”—this tab shows all the calculated constants that are required by the PMSM sensor/sensorless FOC application. It is also possible to generate the *m1_acim_appconfig.h* file, which is then used to preset all application parameters permanently at the project rebuild.
- “App page”—this tab contains the graphical elements like the speed gauge, DC-bus voltage measurement bar, and variety of switches which enable a simple, quick, and user-friendly application control. The fault clearing and the demo mode (which sets various predefined required speeds and positions over time) can be also controlled from here.

Most tabs offer the possibility to immediately load the parameters specified in the MCAT into the target using the “Update target” button and save (or restore) them from the hard drive file using the “Reload Data” and “Store Data” buttons.

The following sections provide simple instructions on how to identify the parameters of a connected PMSM motor and how to appropriately tune the application.

Control structure—“Control Struc” tab

The application can be controlled through the “Control Struc” tab, which is shown in [Figure 28](#). The state control area on the left side of the screen shows the current application state and enables you to turn the main application switch on or off (turning a running application off disables all PWM outputs). The “Cascade Control Structure” area is placed in the right-hand side of the screen. Here you can choose between the scalar control and the FOC control using the appropriate buttons. The selected parts of the FOC cascade structure can be enabled by selecting “Voltage FOC”, “Current FOC”, and “Speed FOC” (sensor/sensorless). This is useful for application tuning and debugging.

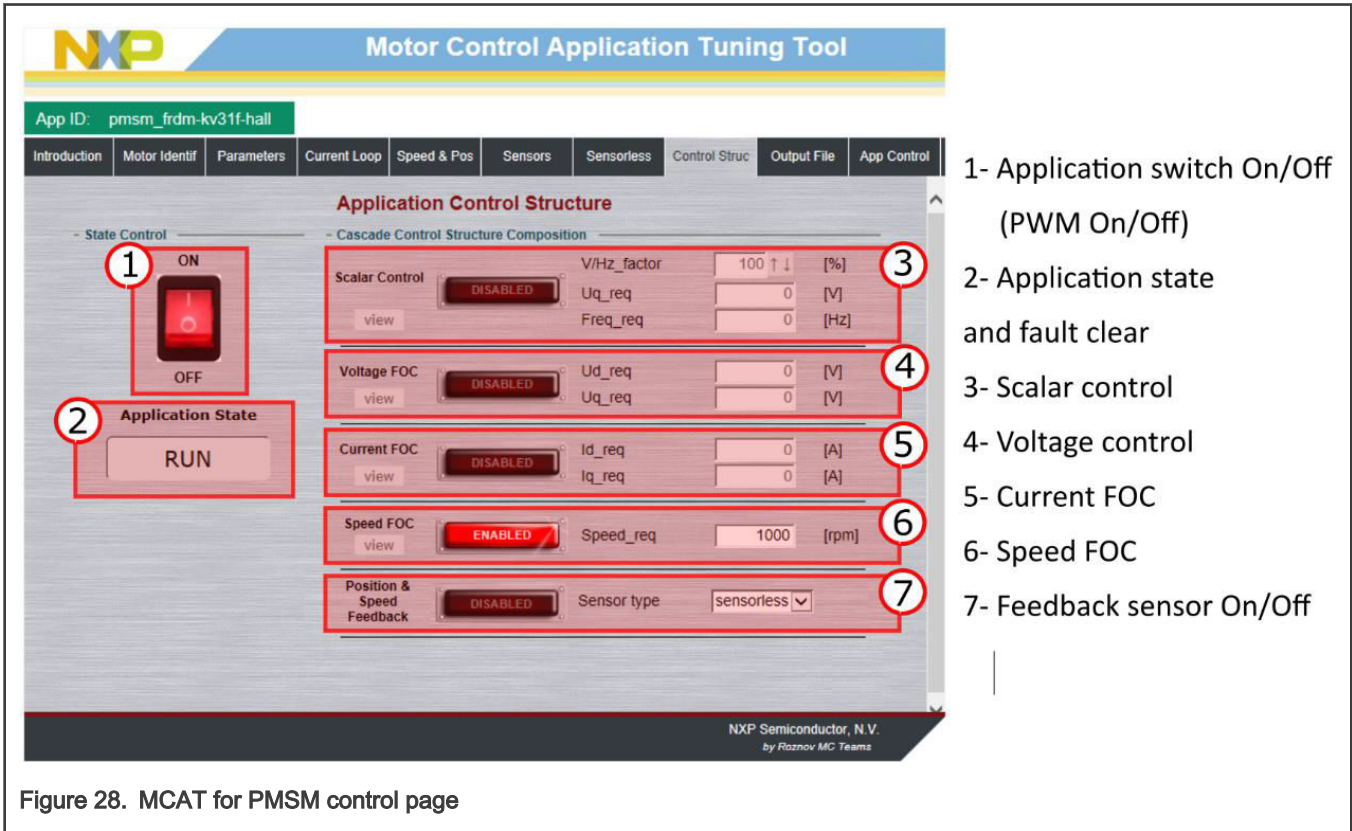

- 1- Application switch On/Off (PWM On/Off)
- 2- Application state and fault clear
- 3- Scalar control
- 4- Voltage control
- 5- Current FOC
- 6- Speed FOC
- 7- Feedback sensor On/Off

Figure 28. MCAT for PMSM control page

The scalar control diagram is shown in [Figure 29](#). It is the simplest type of motor-control techniques. The ratio between the magnitude of the stator voltage and the frequency must be kept at the nominal value. Hence, the control method is sometimes called Volt per Hertz (or V/Hz). The position estimation BEMF observer and tracking observer algorithms (see Sensorless PMSM Field-Oriented Control ([document DRM148](#)) for more information) run in the background, even if the estimated position information is not directly used. This is useful for the BEMF observer tuning.

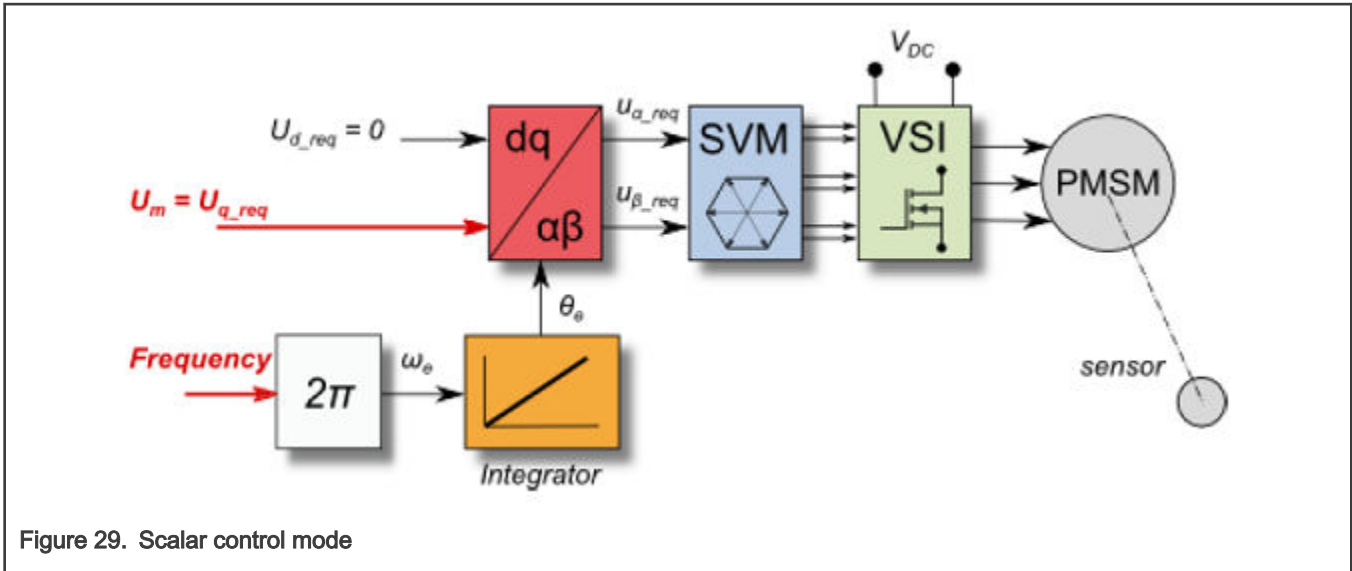

Figure 29. Scalar control mode

The block diagram of the voltage FOC is in Figure 30. Unlike the scalar control, the position feedback is closed using the BEMF observer and the stator voltage magnitude is not dependent on the motor speed. Both the d-axis and q-axis stator voltages can be specified in the “Ud_req” and “Uq_req” fields. This control method is useful for the BEMF observer functionality check.

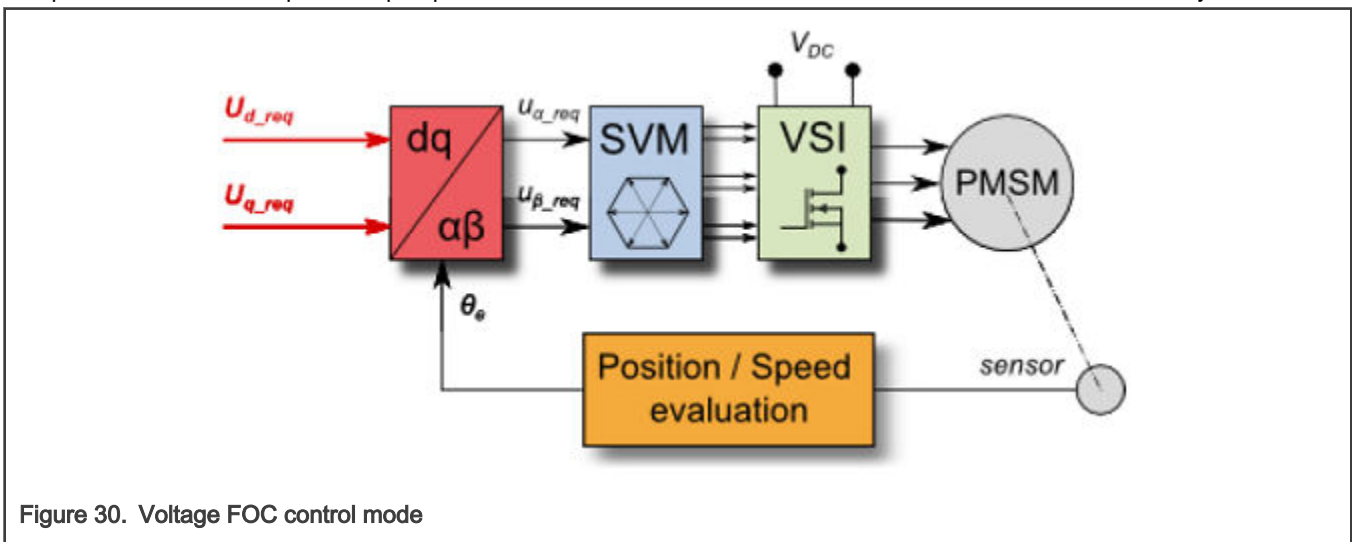

Figure 30. Voltage FOC control mode

The current FOC (or torque) control requires the rotor position feedback and the currents transformed into a d-q reference frame. There are two reference variables (“Id_req” and “Iq_req”) available for the motor control, as shown in the block diagram in Figure 31. The d-axis current component “isd_req” is responsible for the rotor flux control. The q-axis current component of the current “isq_req” generates torque and, by its application, the motor starts running. By changing the polarity of the current “isq_req”, the motor changes the direction of rotation. Supposing that the BEMF observer is tuned correctly, the current PI controllers can be tuned using the current FOC control structure.

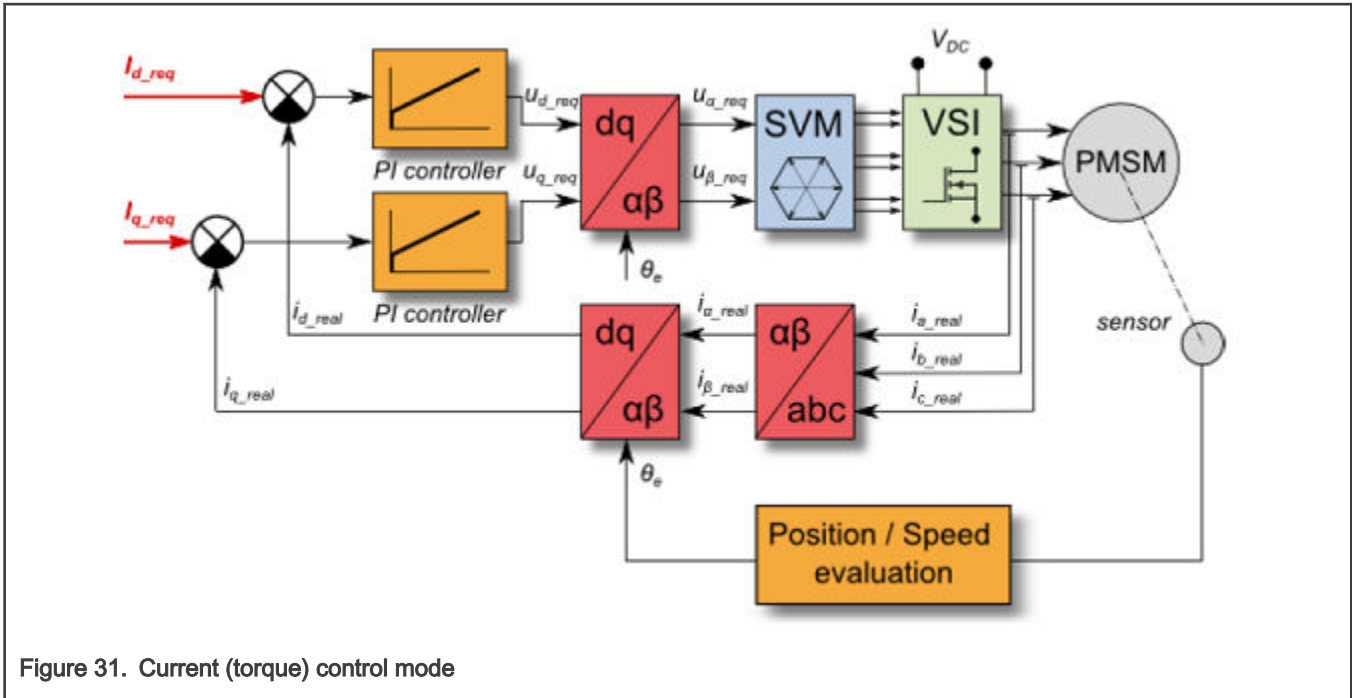

Figure 31. Current (torque) control mode

The speed PMSM sensor/sensorless FOC (its diagram is shown in Figure 32) is activated by enabling the speed FOC control structure. Enter the required speed into the “Speed_req” field. The d-axis current reference is held at 0 during the entire FOC operation.

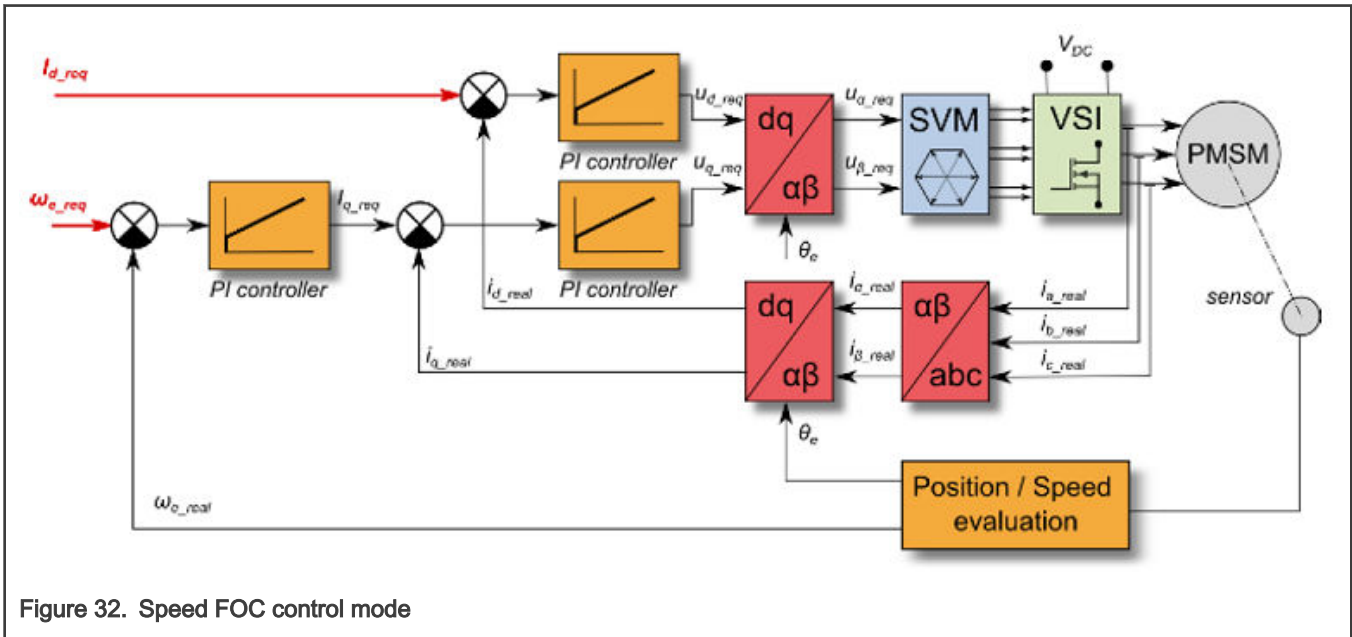

Figure 32. Speed FOC control mode

The position PMSM sensor FOC is shown in Figure 33 (Not available for all devices). The position control using the P controller can be tuned in the “Speed & Pos” menu tab. An encoder sensor is required for the feedback. Without the sensor, the position control does not work. A braking resistor is missing on the FRDM-MC-LVPMMSM board. Therefore, it is needed to set a soft speed ramp (in the “Speed & Pos” menu tab) because the voltage on the DC-bus can rise when braking the quickly spinning shaft. It may cause the overvoltage fault.

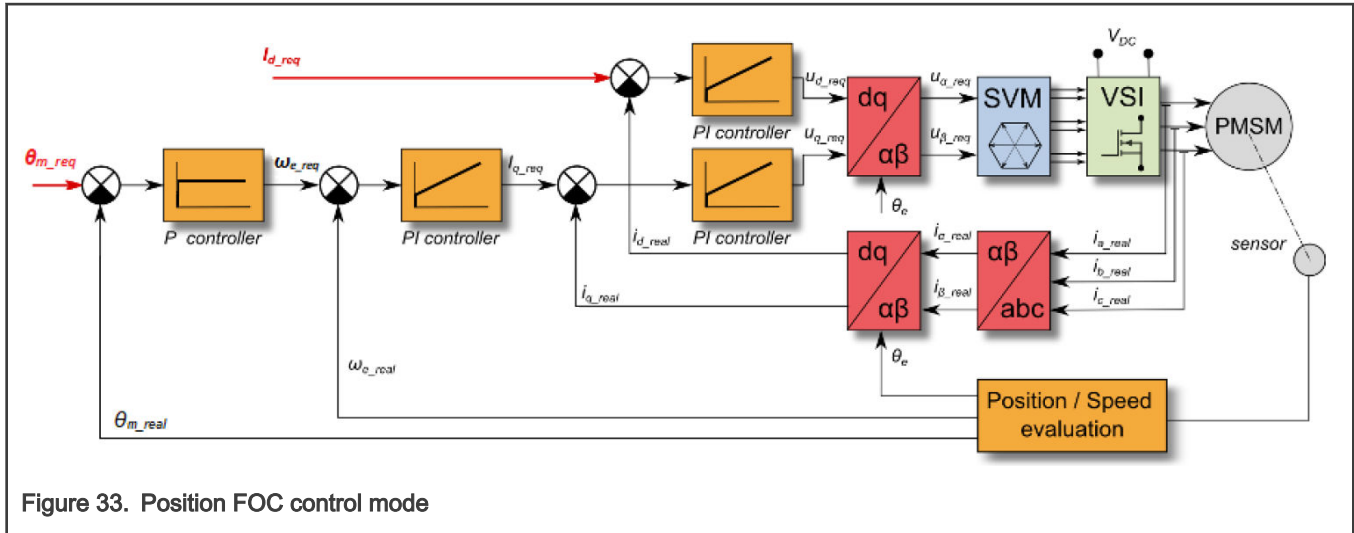

Figure 33. Position FOC control mode

Application demo control—“App control” tab

After launching the application and performing all necessary settings, you can control the PMSM motor using the FreeMASTER application demo control page. This page contains:

- Speed gauge—shows the actual and required speeds.
- Required speed slider—sets up the required speed.
- DC-bus voltage—shows the actual DC-bus voltage.
- Current i_q —shows the actual torque-producing current.
- Current limitation—sets up the torque-producing current limit.
- Demo mode on/off button—turns the demonstration mode on/off.
- RUN/STOP PWM button—runs/stops the whole application (sets the PWM on and off).
- Notification—shows the notification about the actual application state (or faults).

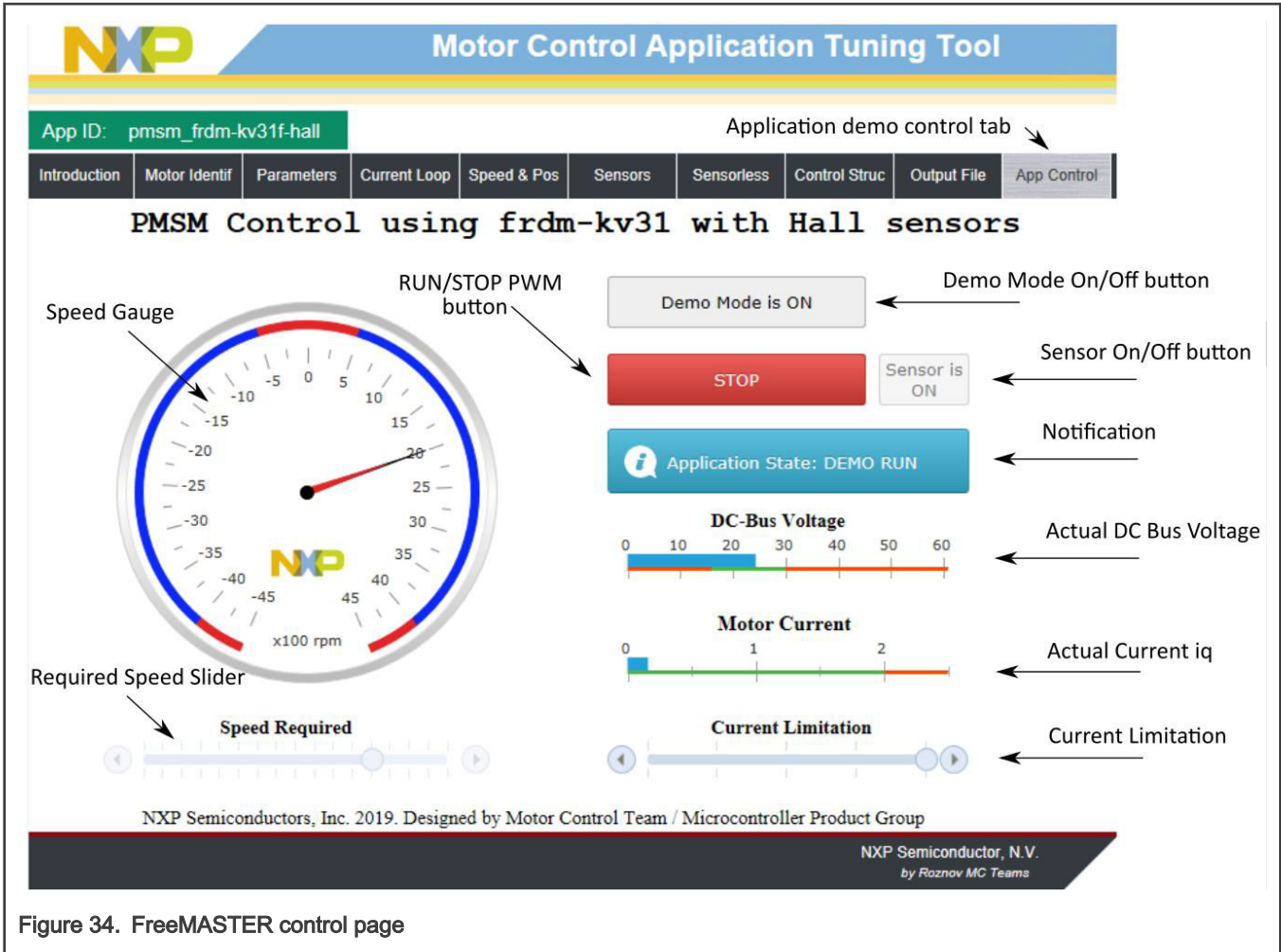

Figure 34. FreeMASTER control page

The following are the basic instructions for controlling a motor:

- To start the motor, set the required speed using the speed slider.
- In case of a fault, click on the fault notification to clear the fault.
- Click the “Demo Mode On/Off” button to turn the demonstration mode on/off.
- Click the “RUN/STOP” button to stop the motor.

Chapter 9

Identifying parameters of user motor using MCAT

This section provides a guide on how to run your own motor or tune the default motor in several steps. It is highly recommended to go through all the steps carefully to eliminate any possible issues during the tuning process. The state diagram in [Figure 35](#) shows a typical PMSM sensor/sensorless control tuning process.

Because the model-based control methods of the PMSM drives are the most effective and usable, obtaining an accurate model of a motor is an important part of the drive design and control. For the implemented FOC algorithms, it is necessary to know the value of the stator resistance R_s , direct inductance L_d , quadrature inductance L_q , and BEMF constant K_e . If your connected PMSM motor is not the default Teknik or Linix motor described in the previous sections, identify the parameters of your motor first. Each tuning phase is described in more detail in the following sections.

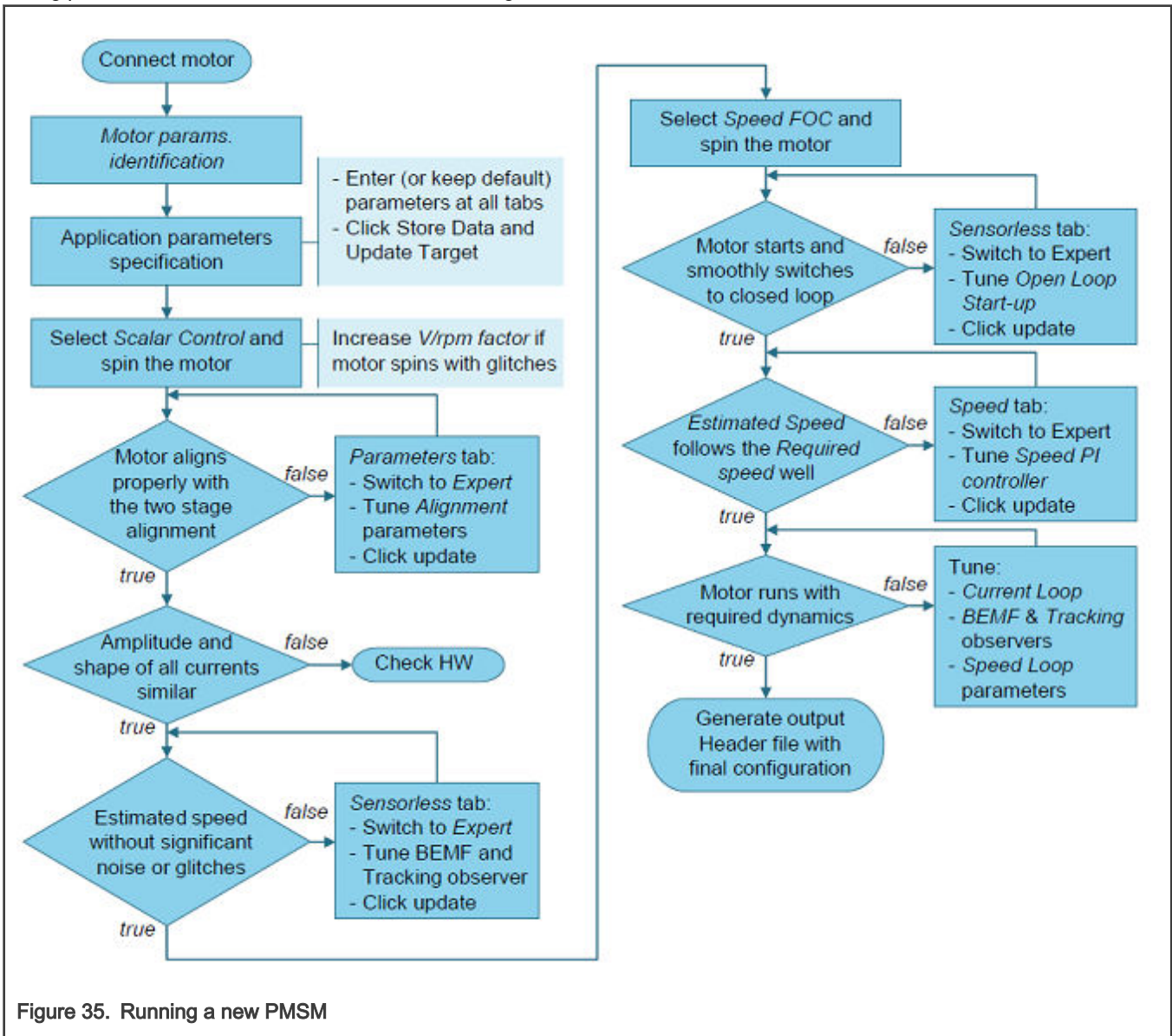

Power stage characterization

Each inverter introduces the total error voltage U_{error} , which is caused by the dead time, current clamping effect, and transistor voltage drop. The total error voltage U_{error} depends on the phase current i_s and this dependency is measured during the power stage characterization process. An example of the inverter error characteristic is shown in Figure 36. The power stage characterization is a part of the MCAT and it can be controlled from the “Motor Identif” tab. To perform the characterization, connect the motor with a known stator resistance R_s and enter this value into the “Calib Rs” field. Then specify the “Calibration Range”, which is the range of the stator current i_s , in which the measurement of U_{error} is performed. Start the characterization by pressing the “Calibrate” button. The characterization gradually performs 65 i_{sd} current steps (from $i_s = -I_{s,calib}$ to $i_s = I_{s,calib}$) with each taking 300 ms, so be aware that the process takes about 20 seconds and the motor must withstand this load. The acquired characterization data is saved to a file and used later for the phase voltage correction during the R_s measurement process. The following R_s measurement can be done with the $I_{s,calib}$ maximum current. It is recommended to use a motor with a low R_s for characterization purposes.

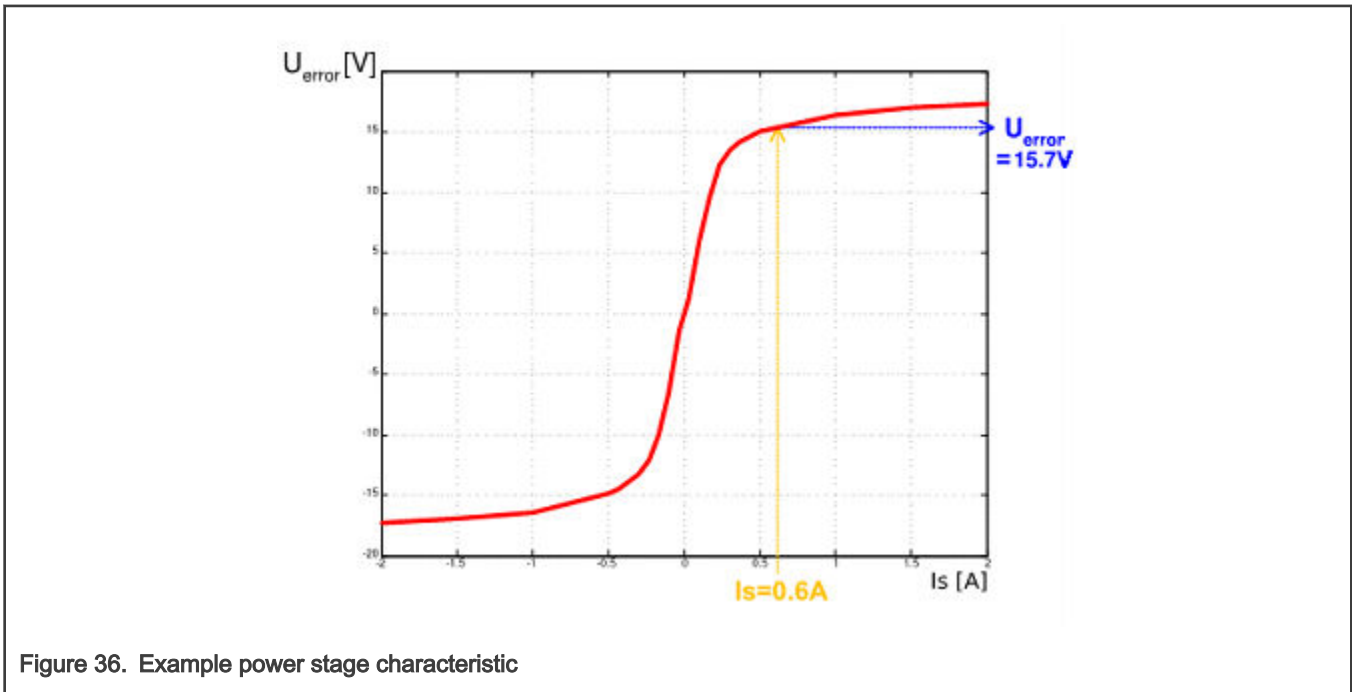

Figure 36. Example power stage characteristic

The power stage characterization is necessary only for the user hardware board. When the NXP power stages (TWR, FRDM, or HVP) are used with the application, the characterization process can be omitted. The acquired characterization data is saved into a file, so it is necessary to do it only once for a given hardware.

Stator resistance measurement

The stator resistance R_s is measured using the DC current I_{phN} value, which is applied to the motor for 1200 ms. The DC voltage U_{DC} is held using current controllers. Their parameters are selected conservatively to ensure stability. The stator resistance R_s is calculated using the Ohm’s law as:

$$R_s = \frac{U_{DC} - U_{error}}{I_{phN}} \text{ [}\Omega\text{]}$$

Stator inductance

For the stator inductance (L_s) identification purposes, a sinusoidal measurement voltage is applied to the motor. During the L_s measurement, the voltage control is enabled. The frequency and amplitude of the sinusoidal voltage are obtained before the actual measurement, during the tuning process. The tuning process begins with a 0-V amplitude and the F_{start} frequency, which are

applied to the motor. The amplitude is gradually increased by $U_d inc$ up to a half of the DC-bus voltage ($DCbus/2$), until $I_d ampl$ is reached. If $I_d ampl$ is not reached even with the $DCbus/2$ and $F start$, the frequency of the measuring signal is gradually decreased by $F dec$ down to $F min$ again, until $I_d ampl$ is reached. If $I_d ampl$ is still not reached, the measurement continues with $DCbus/2$ and $F min$. The tuning process is shown in Figure 37.

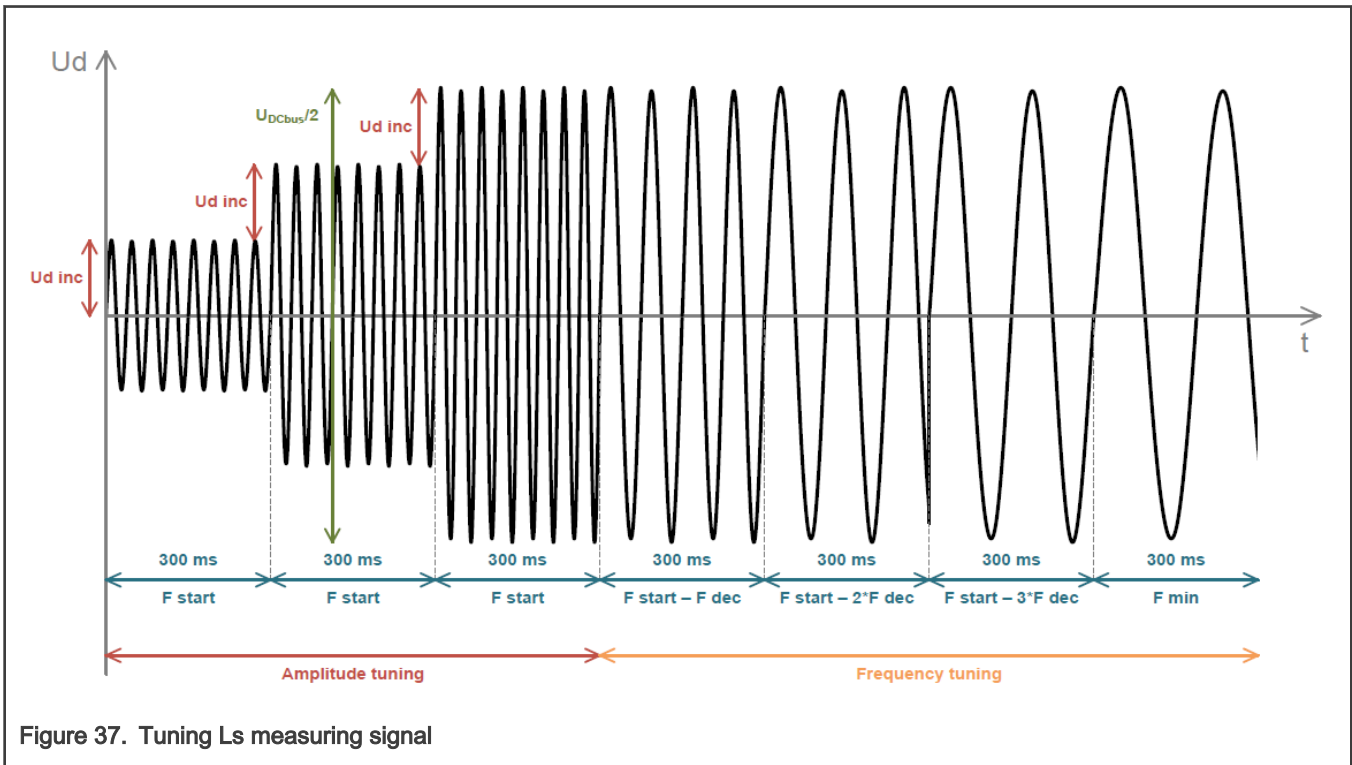

Figure 37. Tuning L_s measuring signal

When the tuning process is complete, the sinusoidal measurement signal (with the amplitude and frequency obtained during the tuning process) is applied to the motor. The total impedance of the RL circuit is then calculated from the voltage and current amplitudes and L_s is calculated from the total impedance of the RL circuit.

$$Z_{RL} = \frac{U_d}{I_{d\ amp}} \text{ [}\Omega\text{]}$$

$$X_{L_s} = \sqrt{Z_{RL}^2 - R_s^2} \text{ [}\Omega\text{]}$$

$$L_s = \frac{X_{L_s}}{2\pi f} \text{ [}\Omega\text{]}$$

The direct inductance L_d and quadrature inductance L_q measurements are made in the same way as L_s . Before the L_d and L_q measurement is made, DC current is applied to the D-axis, which aligns the rotor. For the L_d measurement, the sinusoidal voltage is applied in the D-axis. For the L_q measurement, the sinusoidal voltage is applied in the Q-axis.

BEMF constant measurement

Before the actual BEMF constant (K_e) measurement, the MCAT tool calculates the current controllers and BEMF observer constants from the previously measured R_s , L_d , and L_q . To measure K_e , the motor must spin. I_d is controlled through $I_{d\ meas}$ and the electrical open-loop position is generated by integrating the required speed, which is derived from N_{nom} . When the motor reaches the required speed, the BEMF voltages obtained by the BEMF observer are filtered and K_e is calculated:

$$K_e = \frac{U_{BEMF}}{\omega_{el}} [\Omega]$$

When K_e is being measured, you have to visually check to determine whether the motor is spinning properly. If the motor is not spinning properly, perform these steps:

- Ensure that the number of pp is correct. The required speed for the K_e measurement is also calculated from pp . Therefore, inaccuracy in pp causes inaccuracy in the resulting K_e .
- Increase $I_{d\,meas}$ to produce higher torque when spinning during the open loop.
- Decrease N_{nom} to decrease the required speed for the K_e measurement.

Number of pole-pair assistant

The number of pole-pairs cannot be measured without a position sensor. However, there is a simple assistant to determine the number of pole-pairs (pp). The number of the pp assistant performs one electrical revolution, stops for a few seconds, and then repeats it. Because the pp value is the ratio between the electrical and mechanical speeds, it can be determined as the number of stops per one mechanical revolution. It is recommended not to count the stops during the first mechanical revolution because the alignment occurs during the first revolution and affects the number of stops. During the pp measurement, the current loop is enabled and the I_d current is controlled to $I_{d\,meas}$. The electrical position is generated by integrating the open-loop speed. If the rotor does not move after the start of the number of pp assistant, stop the assistant, increase $I_{d\,meas}$, and restart the assistant.

Mechanical parameters measurement

The moment of inertia J and the viscous friction B can be identified using a test with the known generated torque T and the loading torque T_{load} .

$$\frac{d\omega_m}{dt} = \frac{1}{J} (T - T_{load} - B\omega_m) [\text{rad/s}^2]$$

The ω_m character in the equation is the mechanical speed. The mechanical parameter identification software uses the torque profile. The loading torque is (for simplicity reasons) said to be 0 during the whole measurement. Only the friction and the motor-generated torque are considered. During the first phase of measurement, the constant torque T_{meas} is applied and the motor accelerates to 50 % of its nominal speed in time t_f . These integrals are calculated during the period from t_0 (the speed estimation is accurate enough) to t_f :

$$T_{int} = \int_{t_0}^{t_1} T dt [\text{Nms}]$$

$$\omega_{int} = \int_{t_0}^{t_1} \omega_m dt [\text{rad/s}]$$

During the second phase, the rotor decelerates freely with no generated torque, only by friction. This enables you to simply measure the mechanical time constant $\tau_m = J/B$ as the time in which the rotor decelerates from its original value by 63 %.

The final mechanical parameter estimation can be calculated by integrating:

$$\omega_m(t_1) = \frac{1}{J} T_{int} - B\omega_{int} + \omega_m(t_0) [\text{rad/s}]$$

The moment of inertia is:

$$J = \frac{\tau_m T_{int}}{\tau_m [\omega_m(t_1) - \omega_m(t_0)] + \omega_{int}} [kgm^2]$$

The viscous friction is then derived from the relation between the mechanical time constant and the moment of inertia. To use the mechanical parameters measurement, the current control loop bandwidth $f_{0,Current}$, the speed control loop bandwidth $f_{0,Speed}$, and the mechanical parameters measurement torque Trq_m must be set.

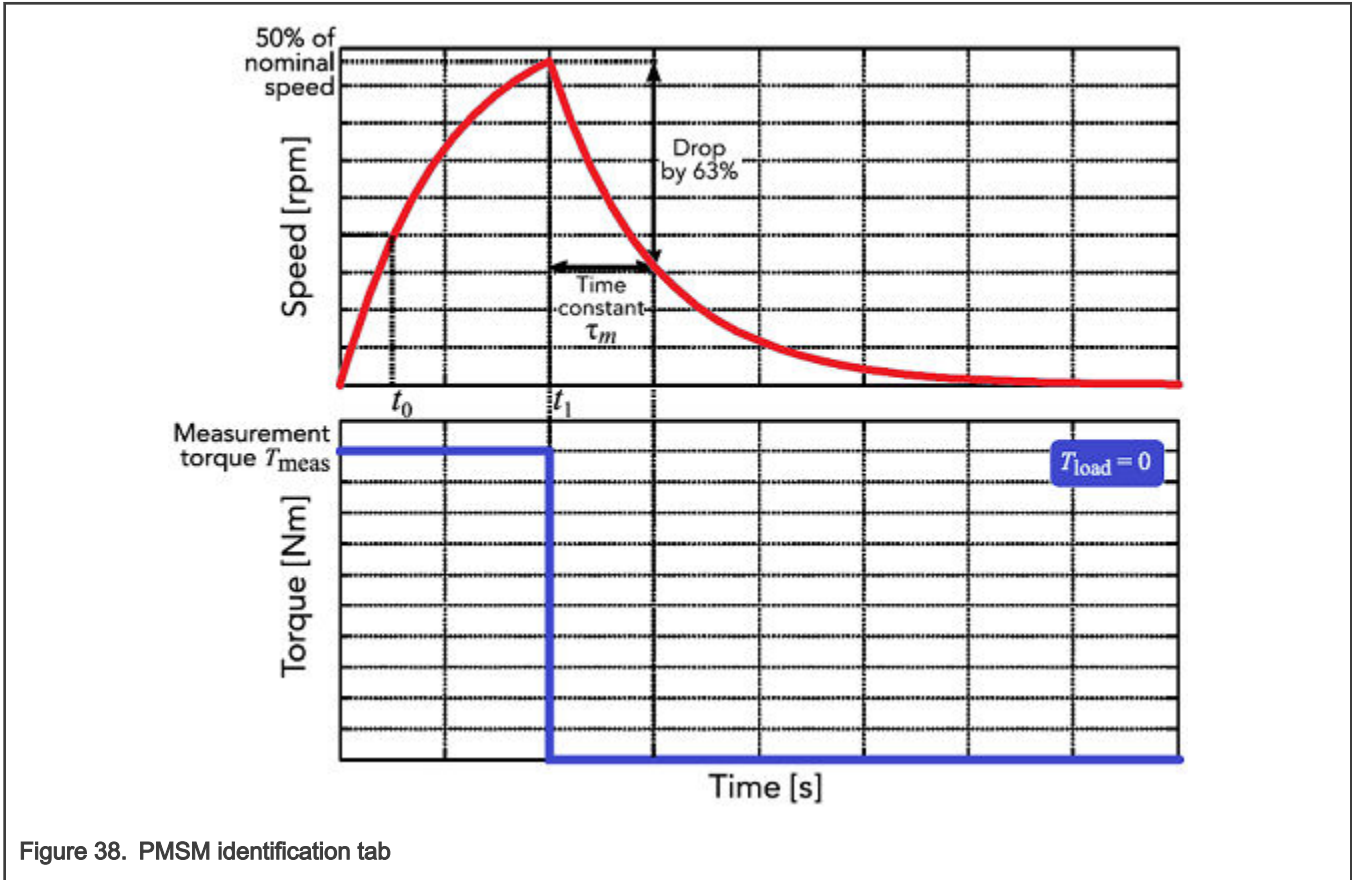

Figure 38. PMSM identification tab

9.1 PMSM electrical and mechanical parameters measurement process

If the parameters of your own motor are known from the datasheet, you can enter them in the "Parameters" tab. If you don't know the parameters of your motor, you have to use automatic parameter identification.

The motor identification process can be controlled and set up in the MCAT "Motor Identif" tab, which is shown in Figure 39. To measure your own motor, follow these steps:

- Select your hardware board. Choose between the standard NXP hardware or use your own. If you use your own hardware, specify its scales ("I max" and "U DCB max" in the "Parameters" menu tab).
- If you don't know the number of motor's pole-pairs, use the number of pole-pair assistant and compute the number of motor rotor stops in one turn.
- If you use your own hardware for the first time (other than NXP boards), perform the power stage characterization.
- Enter the motor measurement parameters and start the measurement by pressing the "Measure electrical" or "Measure mechanical" buttons. You can observe which parameter is being measured in the "Status" bar.

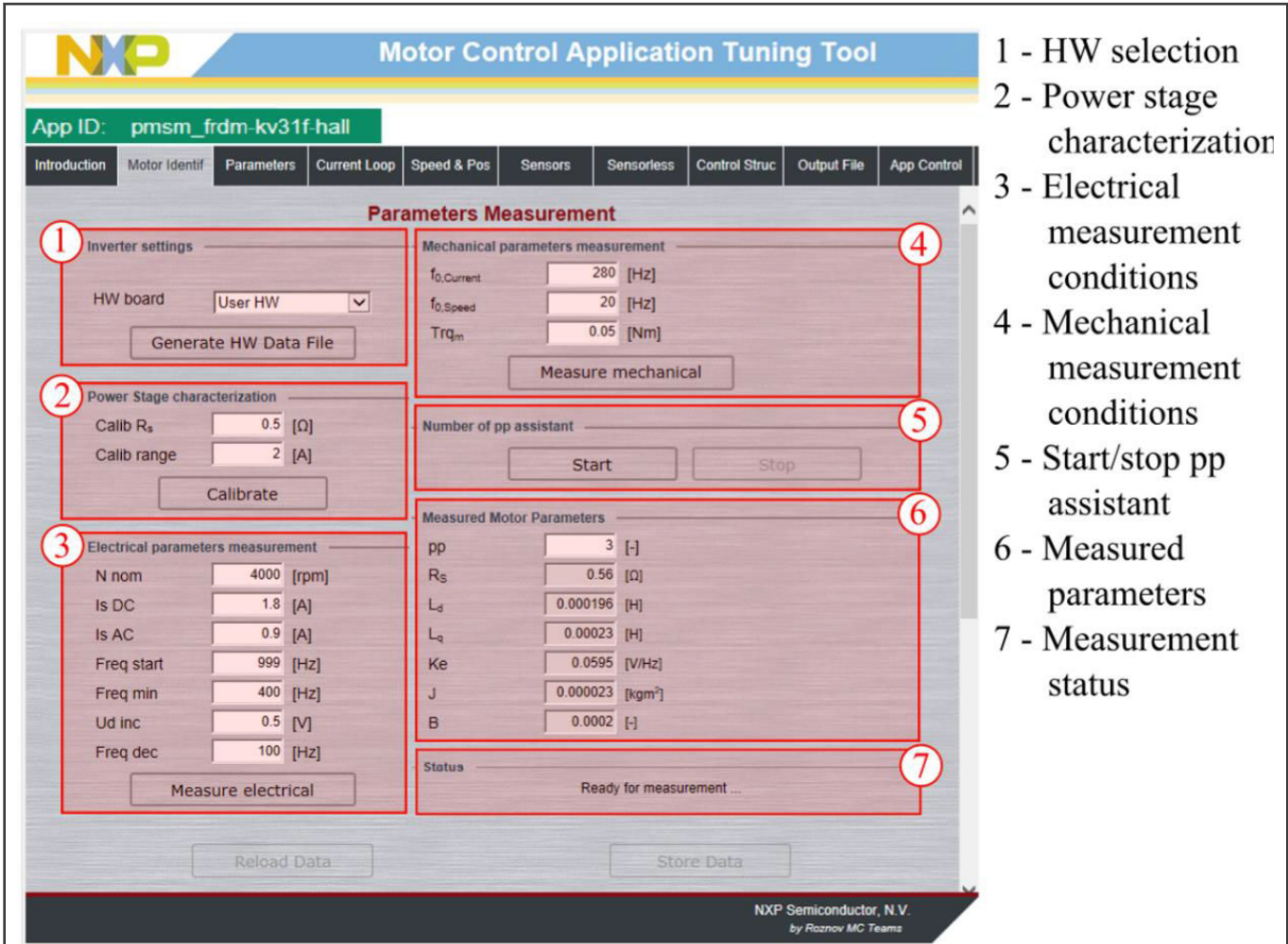

- 1 - HW selection
- 2 - Power stage characterization
- 3 - Electrical measurement conditions
- 4 - Mechanical measurement conditions
- 5 - Start/stop pp assistant
- 6 - Measured parameters
- 7 - Measurement status

Figure 39. PMSM identification tab

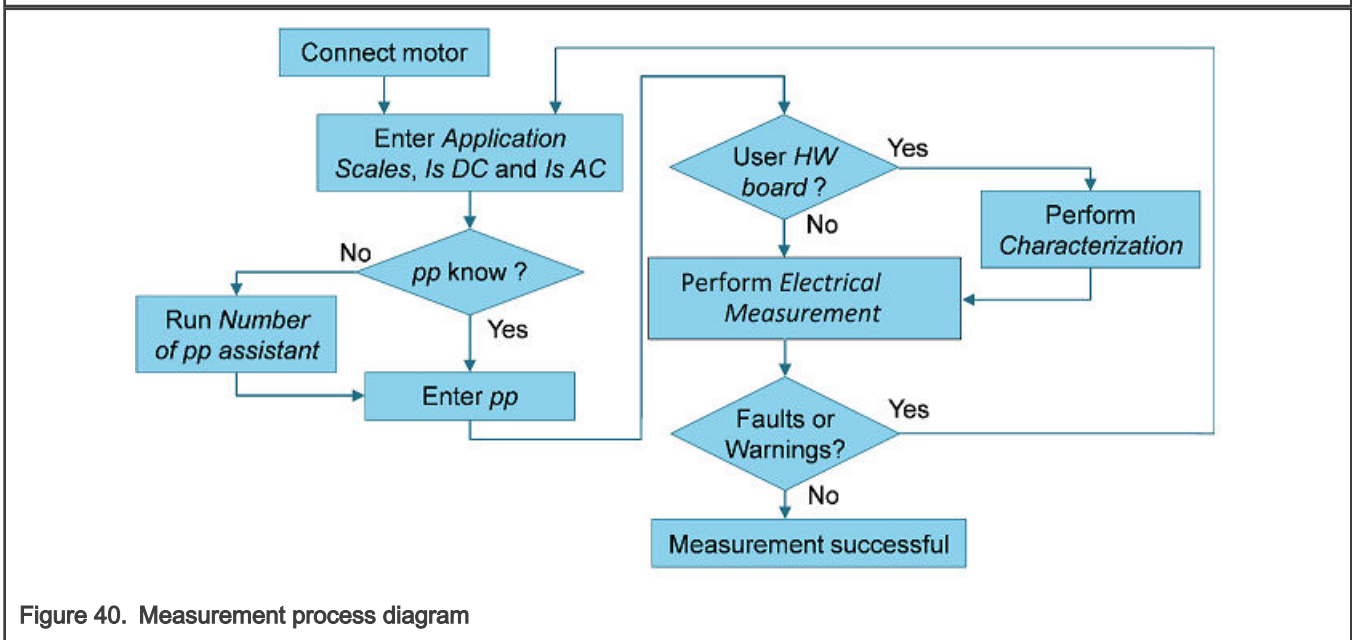

Figure 40. Measurement process diagram

During the measurement, faults and warnings may occur. Do not confuse these faults for the application faults, such as overcurrent, undervoltage, and so on. The list of these faults with their description and possible troubleshooting is shown in [Table 13](#).

Table 13. Measurement faults and warnings

Fault no.	Fault description	Fault reason	Troubleshooting
1	Motor not connected	$I_d > 50$ mA cannot be reached with the available DC-bus voltage.	Check that the motor is connected.
2	R_s too high for calibration	The calibration cannot be reached with the available DC-bus voltage.	Use a motor with a lower R_s for the power stage characterization.
3	Current measurement I_s DC not reached	The user-defined I_s DC was not reached, so the measurement was taken with a lower I_s DC.	Raise the DC-bus voltage to reach the I_s DC or lower the I_s DC to avoid this warning.
4	Current amplitude measurement I_s AC not reached	The user-defined I_s AC was not reached, so the measurement was taken with a lower I_s AC.	Raise the DC-bus voltage or lower the F_{min} to reach the I_s AC or lower the I_s AC to avoid this warning.
5	Wrong characteristic data	The characteristic data, which is used for the voltage correction, does not correspond to the actual power stage.	Select the user hardware and perform the calibration.
6	Mechanical measurement timeout	The mechanical measurement takes too long.	Repeat the measurement process with a different setup.

9.2 Initial configuration setting and update

1. Open the PMSM control application FreeMASTER project containing the dedicated MCAT plug-in module.
2. Select the “Parameters” tab.
3. Leave the measured motor parameters or specify the parameters manually. The motor parameters can be obtained from the motor data sheet or using the PMSM parameters measurement procedure described in *PMSM Electrical Parameters Measurement* (document [AN4680](#)). All parameters provided in [Table 14](#) are accessible. The motor inertia J expresses the overall system inertia and can be obtained using a mechanical measurement. The J parameter is used to calculate the speed controller constant. However, the manual controller tuning can also be used to calculate this constant.

Table 14. MCAT motor parameters

Parameter	Units	Description	Typical range
pp	[-]	Motor pole pairs	1-10
R_s	[Ω]	1-phase stator resistance	0.3-50
L_d	[H]	1-phase direct inductance	0.00001-0.1
L_q	[H]	1-phase quadrature inductance	0.00001-0.1

Table continues on the next page...

Table 14. MCAT motor parameters (continued)

Parameter	Units	Description	Typical range
Ke	[V.sec/rad]	BEMF constant	0.001-1
J	[kg.m ²]	System inertia	0.00001-0.1
I _{ph nom}	[A]	Motor nominal phase current	0.5-8
U _{ph nom}	[V]	Motor nominal phase voltage	10-300
N _{nom}	[rpm]	Motor nominal speed	1000-2000

4. Set the hardware scales—the modification of these two fields is not required when a reference to the standard power stage board is used. These scales express the maximum measurable current and voltage analog quantities.
5. Check the fault limits—these fields are not accessible in the “Basic” mode and are calculated using the motor parameters and hardware scales (see [Table 15](#)).

Table 15. Fault limits

Parameter	Units	Description	Typical range
U DCB trip	[V]	Voltage value at which the external braking resistor switch turns on	U DCB Over ~ U DCB max
U DCB under	[V]	Trigger value at which the undervoltage fault is detected	0 ~ U DCB Over
U DCB over	[V]	Trigger value at which the overvoltage fault is detected	U DCB Under ~ U max
N over	[rpm]	Trigger value at which the overspeed fault is detected	N _{nom} ~ N _{max}
N min	[rpm]	Minimal actual speed value for the sensorless control	(0.05~0.2) * N _{max}

6. Check the application scales—these fields are not accessible in the “Basic” mode and are calculated using the motor parameters and hardware scales.

Table 16. Application scales

Parameter	Units	Description	Typical range
N _{max}	[rpm]	Speed scale	>1.1 * N _{nom}
E _{max}	[V]	BEMF scale	ke * N _{max}
kt	[Nm/A]	Motor torque constant	-

7. Check the alignment parameters—these fields are not accessible in the “Basic” mode and they are calculated using the motor parameters and hardware scales. The parameters express the required voltage value applied to the motor during the rotor alignment and its duration.
8. Click the “Store Data” button to save the modified parameters into the inner file.

9.3 Control structure modes

1. Select the scalar control by clicking the “DISABLED” button in the “Scalar Control” section. The button color changes to red and the text changes to “ENABLED”.
2. Turn the application switch on. The application state changes to “RUN”.

- Set the required frequency value in the “Freq_req” field; for example, 15 Hz in the “Scalar Control” section. The motor starts running (Figure 41).

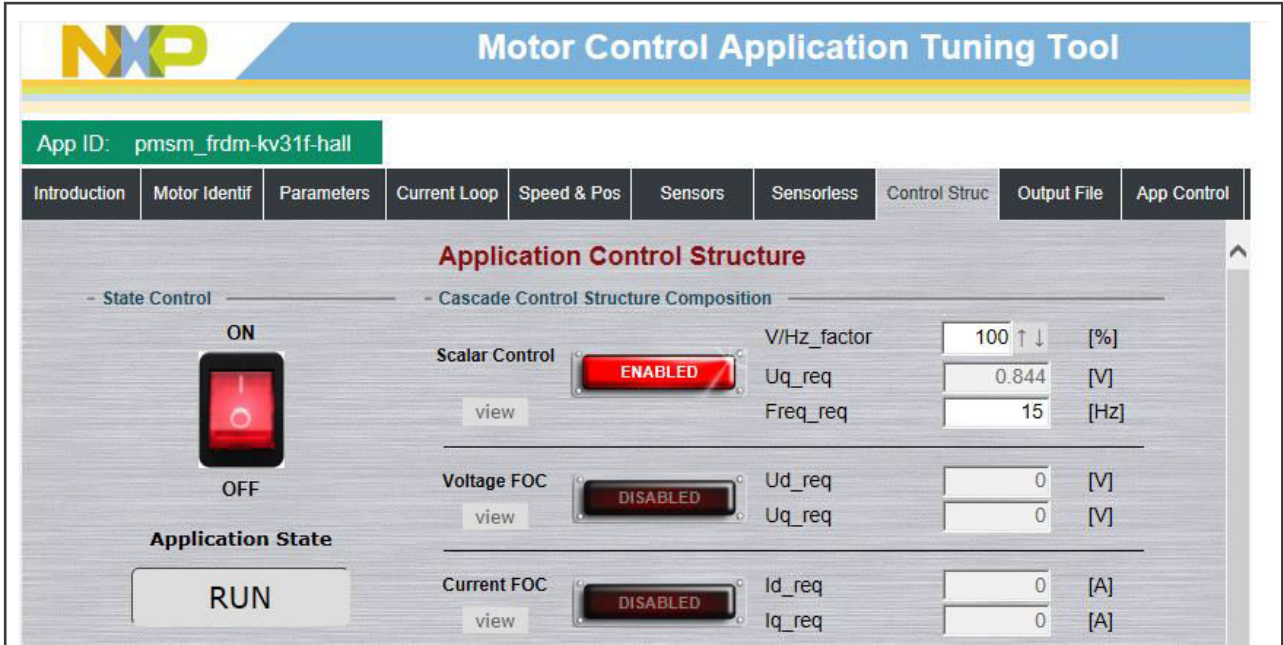

Figure 41. MCAT scalar control

- Select the “Phase Currents” recorder from the “Scalar & Voltage Control” FreeMASTER project tree.
- The optimal ratio for the V/Hz profile can be found by changing the V/Hz factor directly or using the “UP/DOWN” buttons. The shape of the motor currents should be close to a sinusoidal shape (Figure 42).

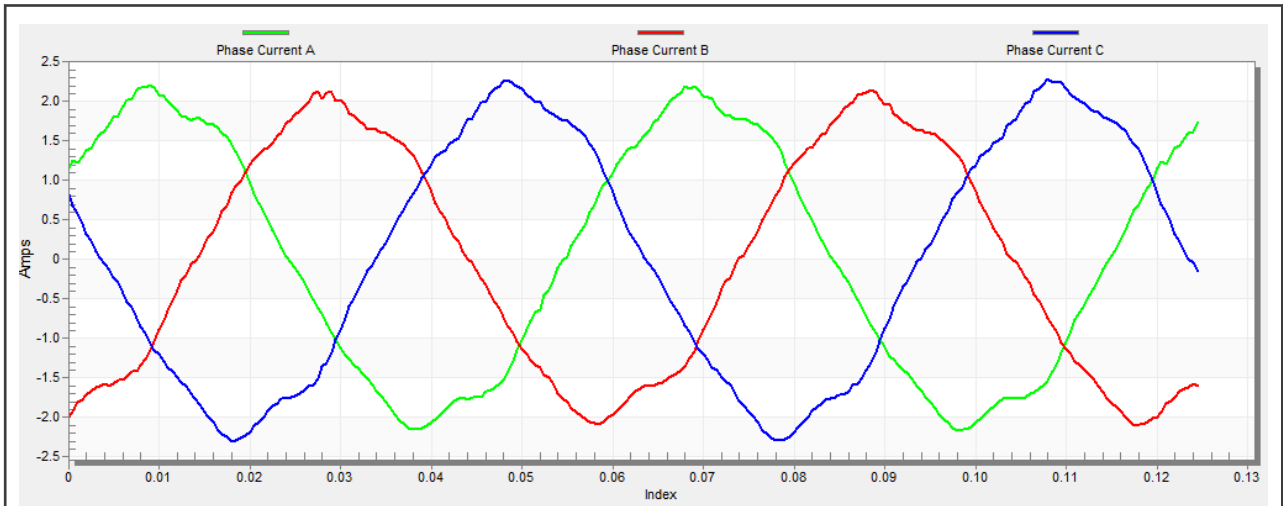

Figure 42. Phase currents

- Select the “Position” recorder to check the observer functionality. The difference between the “Position Electrical Scalar” and the “Position Estimated” should be minimal (see Figure 43) for the Back-EMF position and speed observer to work properly. The position difference depends on the motor load. The higher the load, the bigger the difference between the positions due to the load angle.

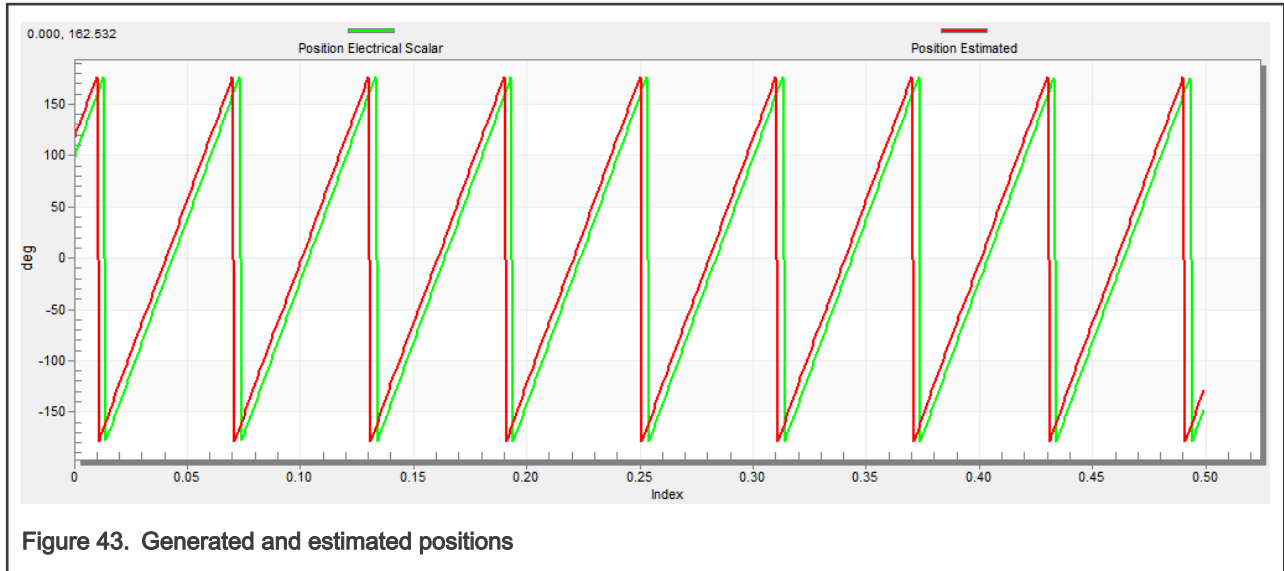

Figure 43. Generated and estimated positions

7. If an opposite speed direction is required, set a negative speed value into the “Freq_req” field.
8. The proper observer functionality and the measurement of analog quantities is expected at this step.
9. Enable the voltage FOC mode by clicking the “DISABLED” button in the “Voltage FOC” section while the main application switch is turned off.
10. Switch the main application switch on and set a non-zero value in the “Uq_req” field. The FOC algorithm uses the estimated position to run the motor.

9.4 Encoder sensor setting

The encoder sensor settings are in the “Sensors” tab. The encoder sensor enables you to compute speed and position for the sensed speed. For a proper encoder counting, set the number of encoder pulses per one revolution and the proper counting direction. The number of encoder pulses is based on information about the encoder from its manufacturer. If the encoder sensor has more pulses per revolution, the speed and position computing is more accurate. The counting direction is provided by connecting the encoder signals to the NXP Freedom board and also by connecting the motor phases. The direction of rotation can be determined as follows:

1. Select the scalar control by clicking the DISABLED button in the “Scalar Control” section of the “Control Struct” tab. The button color changes to red, and the text to “ENABLED”.
2. Turn the application switch on. The application state changes to “RUN”.
3. Set the required frequency value in the “Freq_req” field; for example, 15 Hz in the “Scalar control” section. The motor starts running.
4. Check the encoder direction. Select the “Encoder Direction Scope” from the “Scalar & Voltage Control” project tree. If the encoder direction is right, the estimated speed is equal to the measured mechanical speed. If the measured mechanical speed is opposite to the estimated speed, the direction must be changed by inverting the encoder wires—phase A and phase B (or the other way round).

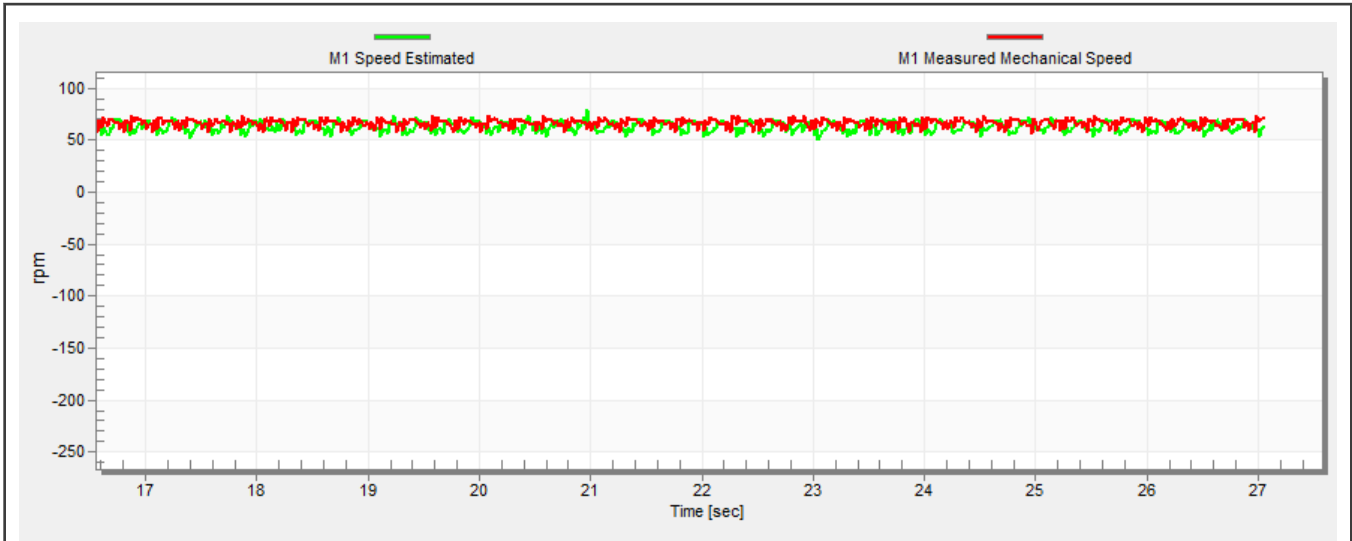

Figure 44. Encoder direction—right direction

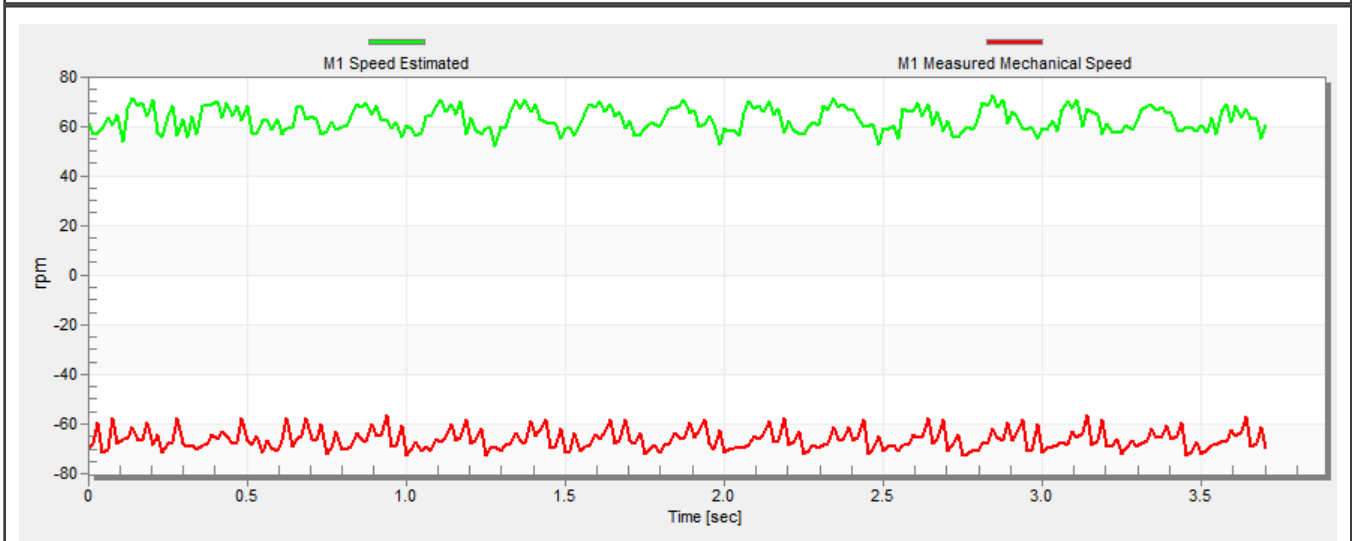

Figure 45. Encoder direction—wrong direction

9.5 Alignment tuning

For the alignment parameters, navigate to the “Tab” menu and select “Parameters”. The alignment procedure sets the rotor to an accurate initial position and enables you to apply full start-up torque to the motor. The rotor-alignment parameters are available for editing in the “Expert” mode. A correct initial position is needed mainly for high start-up loads (compressors, washers, and so on). The aim of the alignment is to have the rotor in a stable position, without any oscillations before the startup.

1. The alignment voltage is the value applied to the d-axis during the alignment. Increase this value for a higher shaft load.
2. The alignment duration expresses the time when the alignment routine is called. Tune this parameter to eliminate rotor oscillations or movement at the end of the alignment process.

9.6 Current loop tuning

The parameters for the current D, Q, and PI controllers are fully calculated in the “Basic” mode using the motor parameters and no action is required in this mode. If the calculated loop parameters do not correspond to the required response, the bandwidth and attenuation parameters can be tuned.

1. Lock the motor shaft.
2. Set the required loop bandwidth and attenuation and click the “Update Target” button in the “Current Loop” tab. The tuning loop bandwidth parameter defines how fast the loop response is whilst the tuning loop attenuation parameter defines the actual quantity overshoot magnitude.
3. Select the “Current Controller Id” recorder.
4. Select the “Control Structure” tab, switch to “Current FOC”, set the “Iq_req” field to a very low value (for example 0.01), and set the required step in “Id_req”. The control loop response is shown in the recorder.
5. Tune the loop bandwidth and attenuation until you achieve the required response. The example waveforms show the correct and incorrect settings of the current loop parameters:

- The loop bandwidth is low (110 Hz) and the settling time of the Id current is long (Figure 46).

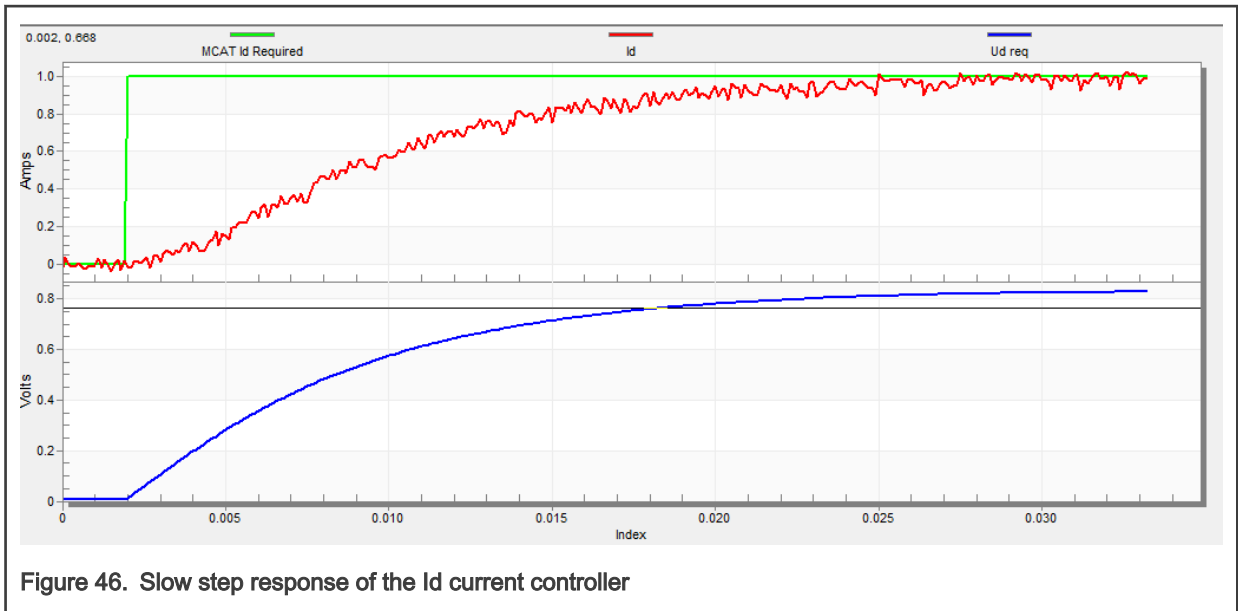

- The loop bandwidth (400 Hz) is optimal and the response time of the Id current is sufficient (see Figure 47).

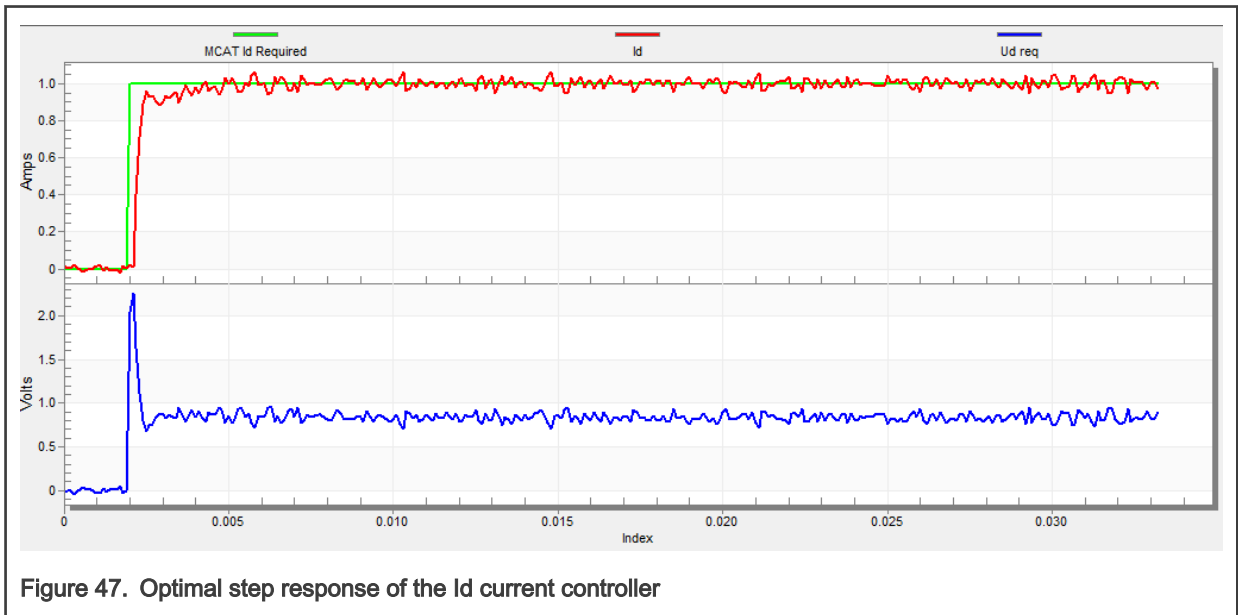

- The loop bandwidth is high (700 Hz) and the response time of the Id current is very fast, but with oscillation and overshoot (see Figure 48).

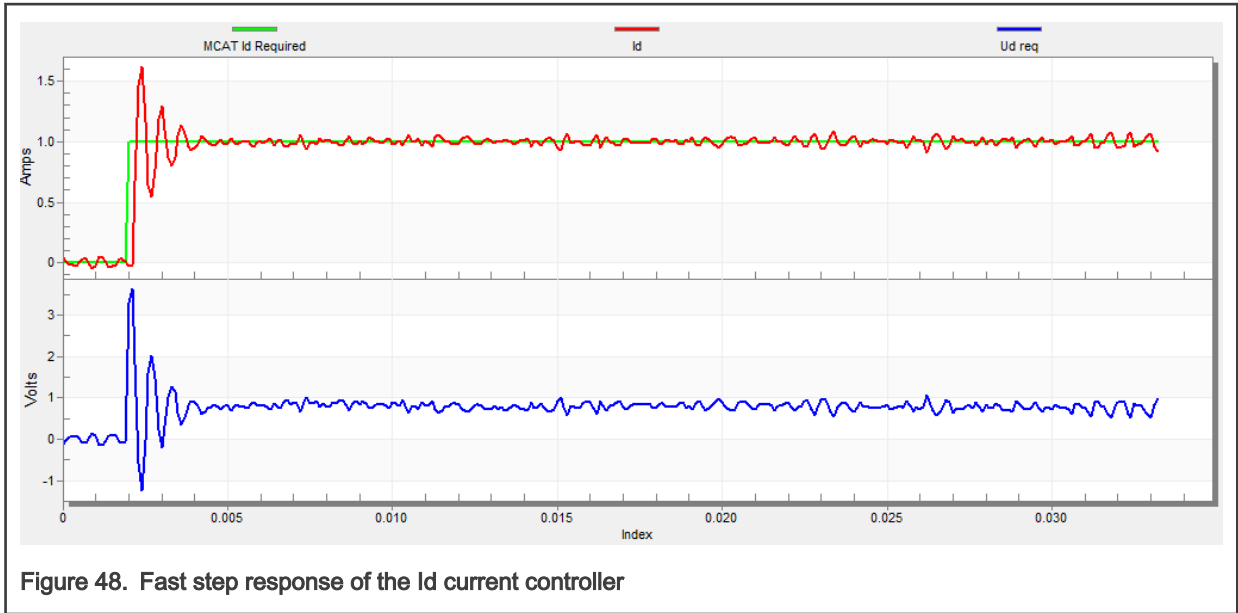

9.7 Speed ramp tuning

1. The speed command is applied to the speed controller through a speed ramp. The ramp function contains two increments (up and down) which express the motor acceleration and deceleration per second. If the increments are very high, they can cause an overcurrent fault during acceleration and an overvoltage fault during deceleration. In the “Speed” scope, you can see whether the “Speed Actual Filtered” waveform shape equals the “Speed Ramp” profile.
2. The increments are common for the scalar and speed control. The increment fields are in the “Speed & Pos” tab and accessible in both tuning modes. Clicking the “Update Target” button applies the changes to the MCU. An example speed profile is shown in Figure 49. The ramp increment down is set to 500 rpm/sec and the increment up is set to 3000 rpm/sec.
3. The start-up ramp increment is in the “Sensorless” tab and its value is usually higher than that of the speed loop ramp.

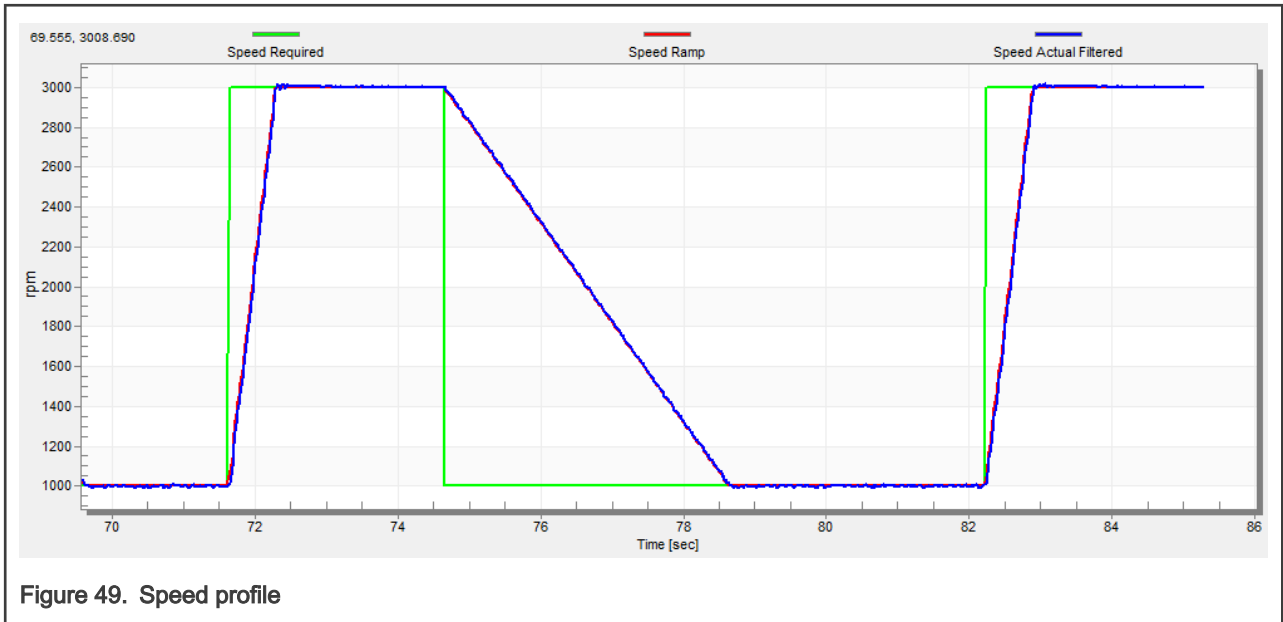

9.8 Open loop startup

1. The start-up process can be tuned by a set of parameters located in the “Sensorless” tab. Two of them (ramp increment and current) are accessible in both tuning modes. The start-up tuning can be processed in all control modes besides the scalar control. Setting the optimal values results in a proper motor startup. An example start-up state of low-dynamic drives (fans, pumps) is shown in [Figure 50](#).
2. Select the “Startup” recorder from the FreeMASTER project tree.
3. Set the start-up ramp increment typically to a higher value than the speed-loop ramp increment.
4. Set the start-up current according to the required start-up torque. For drives such as fans or pumps, the start-up torque is not very high and can be set to 15 % of the nominal current.
5. Set the required merging speed—when the open-loop and estimated position merging starts, the threshold is mostly set in the range of 5 % ~ 10 % of the nominal speed.
6. Set the merging coefficient—in the position merging process duration, 100 % corresponds to a half of an electrical revolution. The higher the value, the faster the merge. Values close to 1 % are set for the drives where a high start-up torque and smooth transitions between the open loop and the closed loop are required.
7. Click the “Update Target” button to apply the changes to the MCU.
8. Switch to the “Control Structure” tab, and enable the “Speed FOC”.
9. Set the required speed higher than the merging speed.
10. Check the start-up response in the recorder.
11. Tune the start-up parameters until you achieve an optimal response.
12. If the rotor does not start running, increase the start-up current.
13. If the merging process fails (the rotor is stuck or stopped), decrease the start-up ramp increment, increase the merging speed, and set the merging coefficient to 5 %.

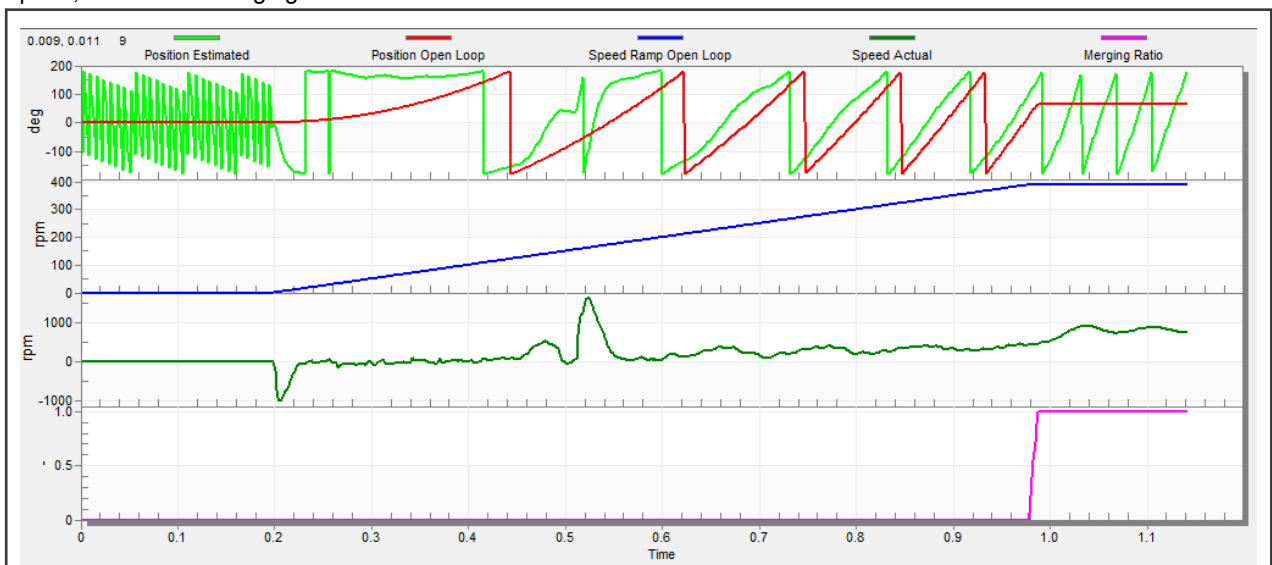

Figure 50. Motor startup

9.9 BEMF observer tuning

1. In the “Basic” mode, the parameters of the BEMF observer and the tracking observer are fully calculated using the motor parameters and no action is required. If the calculated loop parameters do not correspond to the optimal response, the bandwidth and attenuation parameters can be tuned.
2. Select the “Observer” recorder from the FreeMASTER project tree.

3. Set the required bandwidth and attenuation of the BEMF observer—the bandwidth is typically set to a value close to the current loop bandwidth.
4. Set the required bandwidth and attenuation of the tracking observer—the bandwidth is typically set in the range of 10 – 20 Hz for most low-dynamic drives (fans, pumps).
5. Click the “Update Target” button to apply the changes to the MCU.
6. Check the observer response in the recorder.

9.10 Speed PI controller tuning

The motor speed control loop is a first-order function with a mechanical time constant that depends on the motor inertia and friction. If the mechanical constant is available, the PI controller constants can be tuned using the loop bandwidth and attenuation. Otherwise, the manual tuning of the P and I portions of the speed controllers is available to obtain the required speed response (see the example response in [Figure 51](#)). There are dozens of approaches to tune the PI controller constants. The following steps provide an approach to set and tune the speed PI controller for a PM synchronous motor:

1. Select the “Speed Controller” option from the FreeMASTER project tree.
2. Select the “Speed & Pos” tab.
3. Check the “Manual Constant Tuning” option—that is, the “Bandwidth” and “Attenuation” fields are disabled and the “SL_Kp” and “SL_Ki” fields are enabled.
4. Tune the proportional gain:
 - Set the “SL_Ki” integral gain to 0.
 - Set the speed ramp to 1000 rpm/sec (or higher).
 - Switch to the “Control Structure” tab and run the motor at a convenient speed (about 30 % of the nominal speed).
 - Set a step in the required speed to 40 % of N_{nom} .
 - Switch back to the “Speed loop” tab.
 - Adjust the proportional gain “SL_Kp” until the system responds to the required value properly and without any oscillations or excessive overshoot:
 - If the “SL_Kp” field is set low, the system response is slow.
 - If the “SL_Kp” field is set high, the system response is tighter.
 - When the “SL_Ki” field is 0, the system most probably does not achieve the required speed.
 - Click the “Update Target” button to apply the changes to the MCU.
5. Tune the integral gain:
 - Increase the “SL_Ki” field slowly to minimize the difference between the required and actual speeds to 0.
 - Adjust the “SL_Ki” field such that you do not see any oscillation or large overshoot of the actual speed value while the required speed step is applied.
 - Click the “Update Target” button to apply the changes to the MCU.
6. Tune the loop bandwidth and attenuation until the required response is received. The example waveforms with the correct and incorrect settings of the speed loop parameters are shown in the following figures:
 - The “SL_Ki” value is low and the “Speed Actual Filtered” does not achieve the “Speed Ramp” (see [Figure 51](#)).

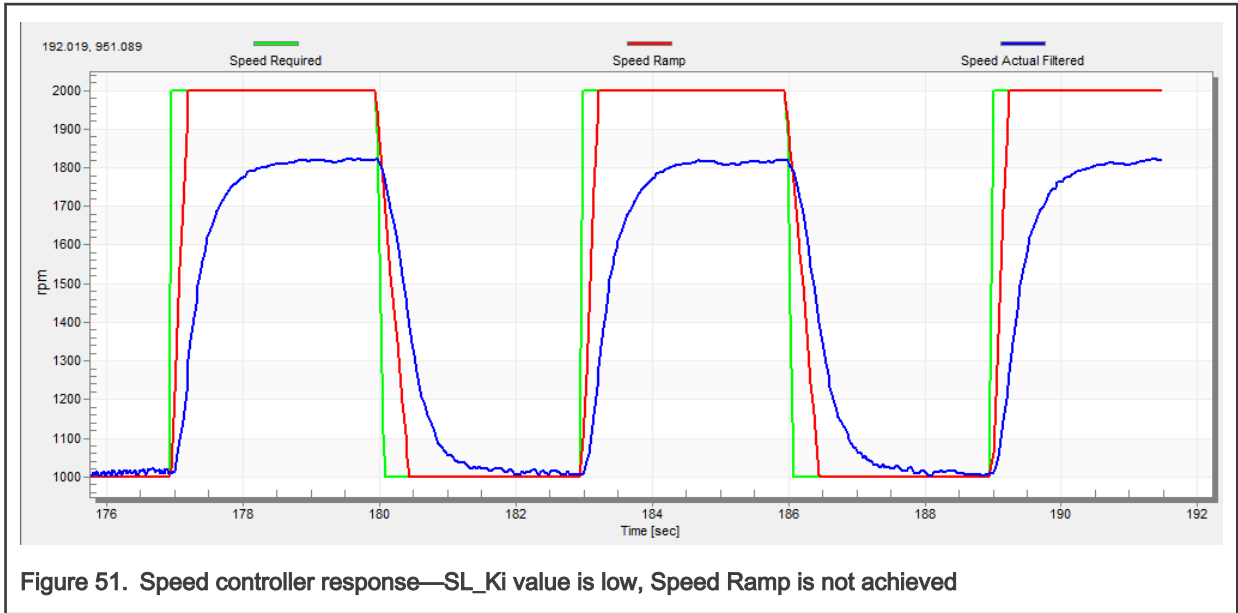

- The “ SL_{Kp} ” value is low, the “Speed Actual Filtered” greatly overshoots, and the long settling time is unwanted (see Figure 52).



- The speed loop response has a small overshoot and the “Speed Actual Filtered” settling time is sufficient. Such response can be considered optimal (see Figure 53).

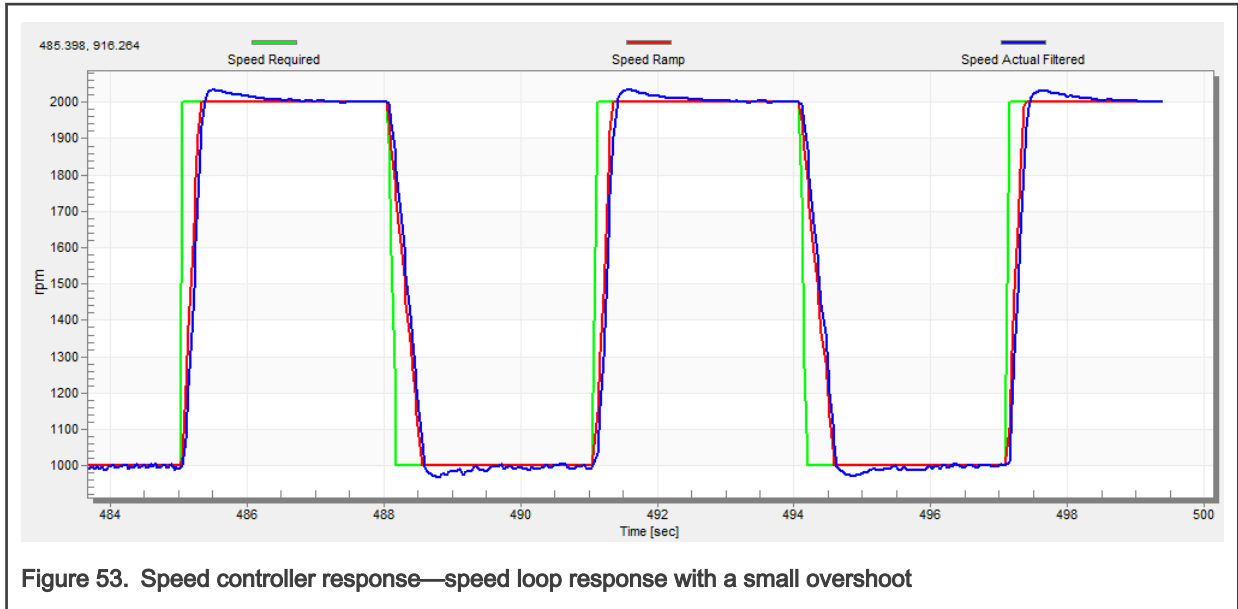

9.11 Position P controller tuning

The position control loop can be tuned using the proportional gain “PL_Kp” in the “Speed & Pos” menu tab. It is a proportional controller that can be used to unpretend the position-control systems. The key for the the optimal position response is a proper value of the controller, which simply multiplies the error by the proportional gain (K_p) to get the controller output. The predefined base value can be manually changed. An encoder sensor must be used for a working position control. The following steps provide an example of how to set the position P controller for a PM synchronous motor:

1. Select the “Position Controller” from the FreeMASTER project tree.
2. Select the “Speed & Pos” tab.
3. Tune the proportional gain in the position P controller constant:
 - Set a small value of “PL_Kp” (M1 Position Loop Kp Gain) and click the “Update Target” button.
 - Switch to “Control structure”, select the position control, and set the required position (for example; 10 revolutions).
 - Select the “Position Controller” and watch the actual position response.
4. Repeat the previous steps until you achieve the required position response.

The “PL_Kp” value is low and the actual position response on the required position is very slow.

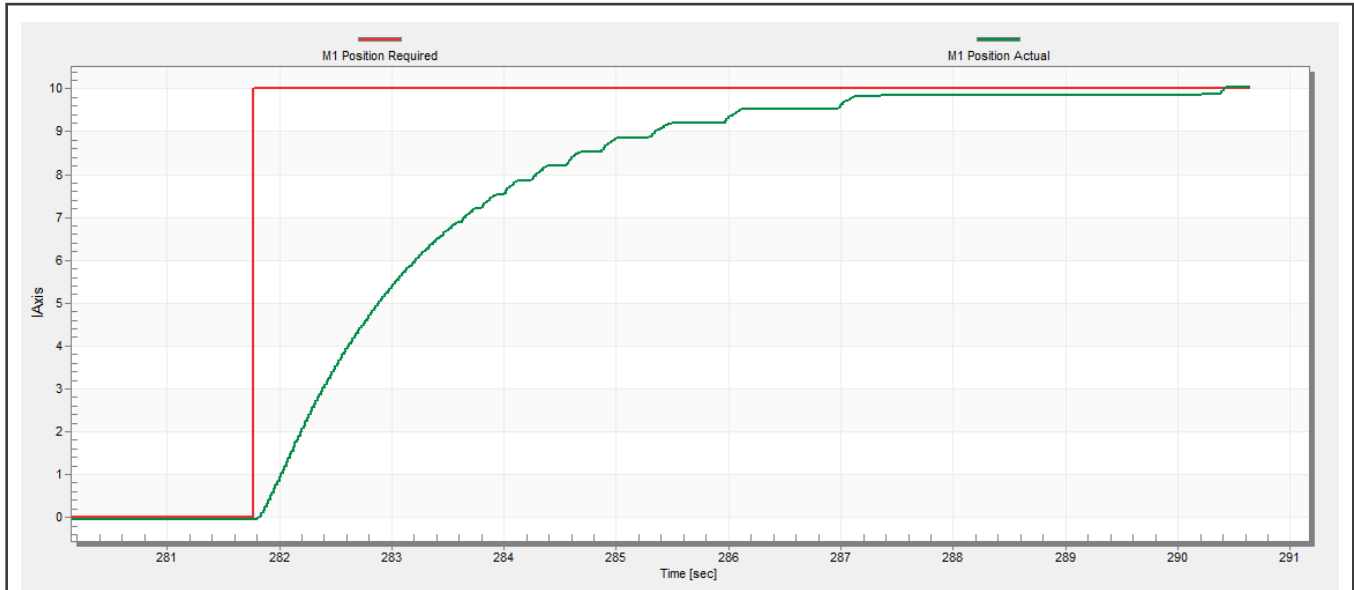

Figure 54. Position controller response—PL_Kp value is low, the actual position response is very slow

The “PL_Kp” value is too high and the actual position overshoots the required position.

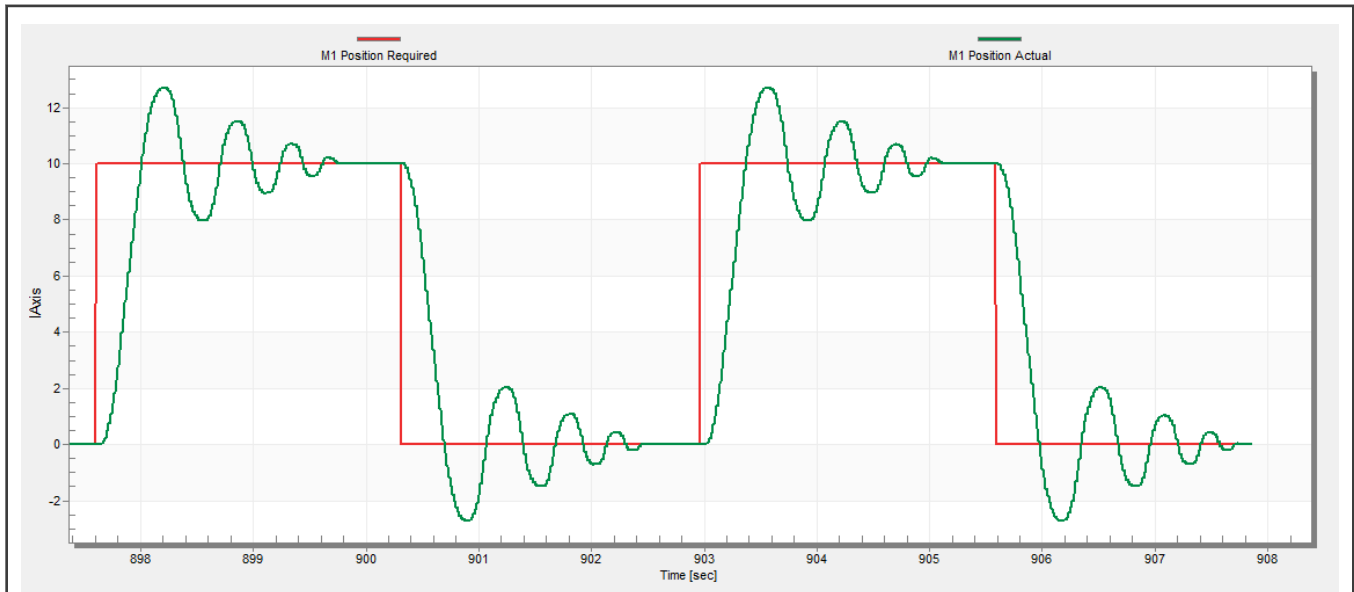

Figure 55. Position controller response—PL_Kp value is too high and the actual position overshoots

The “PL_Kp” value and the actual position response are optimal.

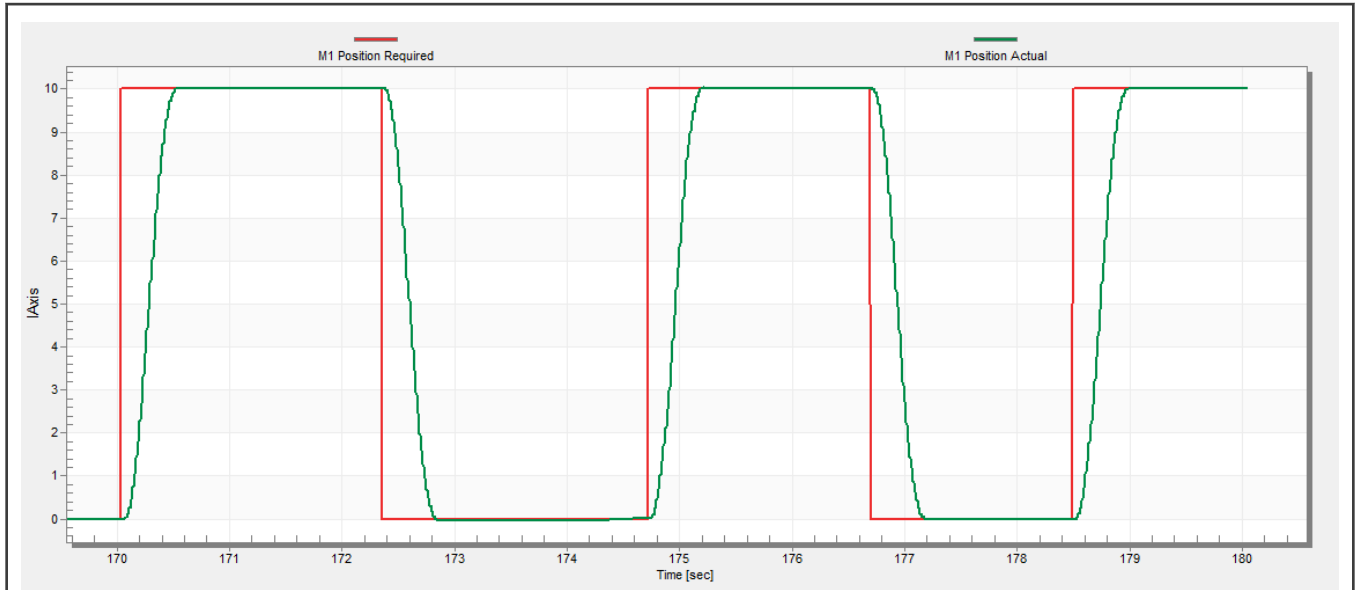

Figure 56. Position controller response—the actual position response is good

Chapter 10

Conclusion

This application note describes the implementation of the sensor and sensorless Field-Oriented Control of a 3-phase PMSM on the NXP MIMXRT1xxx EVK board with the FRDM-MC-LVPMSM NXP Freedom Development Platform. The hardware-dependent part of the control software is described in [Hardware setup](#). The motor-control application timing is described in [RT crossover processors features and peripheral settings](#) and the peripheral initialization is described in [Motor-control peripheral initialization](#). The motor user interface and remote control using FreeMASTER are as follows. The motor parameters identification theory and the identification algorithms are described in [Identifying parameters of user motor using MCAT](#).

Chapter 11

Acronyms and abbreviations

Table 17. Acronyms and abbreviations

Acronym	Meaning
ADC	Analog-to-Digital Converter
ACIM	Asynchronous Induction Motor
ADC_ETC	ADC External Trigger Control
AN	Application Note
BLDC	Brushless DC motor
CCM	Clock Controller Module
CPU	Central Processing Unit
DC	Direct Current
DRM	Design Reference Manual
ENC	Encoder
FOC	Field-Oriented Control
GPIO	General-Purpose Input/Output
LPUART	Low-Power Universal Asynchronous Receiver/Transmitter
MCAT	Motor Control Application Tuning tool
MCDRV	Motor Control Peripheral Drivers
MCU	Microcontroller
PI	Proportional Integral controller
PLL	Phase-Locked Loop
PMSM	Permanent Magnet Synchronous Machine
PWM	Pulse-Width Modulation
QD	Quadrature Decoder
TMR	Quad Timer
USB	Universal Serial Bus
XBAR	Inter-Peripheral Crossbar Switch

Chapter 12

References

These references are available on www.nxp.com:

1. *Sensorless PMSM Field-Oriented Control* (document [DRM148](#))
2. *Motor Control Application Tuning (MCAT) Tool for 3-Phase PMSM* (document [AN4642](#))
3. *PMSM Field-Oriented Control on MIMXRT10xx EVK User's Guide* (document [PMSMFOCRT10xxUG](#))
4. *PMSM Field-Oriented Control on MIMXRT10xx EVK* (document [AN12214](#))

Chapter 13

Useful links

1. PMSM Control Reference Design www.nxp.com/motorcontrol_pmsm
2. BLDC Control Reference Design www.nxp.com/motorcontrol_bldc
3. ACIM Control Reference Design www.nxp.com/motorcontrol_acim
4. [i.MX RT1024-EVK board](#)
5. [i.MX RT1060-EVK board](#)
6. [i.MX RT1064-EVK board](#)
7. [i.MX RT1160-EVK board](#)
8. [i.MX RT1170-EVK board](#)
9. [i.MX RT Crossover MCUs](#)
10. [FRDM-MC-PMSM Freedom Development Platform](#)
11. [MCUXpresso IDE - Importing MCUXpresso SDK](#)
12. MCUXpresso SDK Builder (SDK examples in several IDEs) <https://mcuxpresso.nxp.com/en/welcome>

Chapter 14

Revision history

Table 18 summarizes the changes done to the document since the initial release.

Table 18. Revision history

Revision number	Date	Substantive changes
0	02/2020	Initial release
1	06/2020	Added MIMXRT1010-EVK
2	01/2021	Added MIMXRT1024-EVK and MIMXRT1170-EVK
3	07/2021	Added MIMXRT1060-EVKB, MIMXRT1064-EVK and MIMXRT1160-EVK. Removed MIMXRT1010-EVK, MIMXRT1020-EVK and MIMXRT1050-EVKB.

How To Reach Us

Home Page:

nxp.com

Web Support:

nxp.com/support

Information in this document is provided solely to enable system and software implementers to use NXP products. There are no express or implied copyright licenses granted hereunder to design or fabricate any integrated circuits based on the information in this document. NXP reserves the right to make changes without further notice to any products herein.

NXP makes no warranty, representation, or guarantee regarding the suitability of its products for any particular purpose, nor does NXP assume any liability arising out of the application or use of any product or circuit, and specifically disclaims any and all liability, including without limitation consequential or incidental damages. "Typical" parameters that may be provided in NXP data sheets and/or specifications can and do vary in different applications, and actual performance may vary over time. All operating parameters, including "typicals," must be validated for each customer application by customer's technical experts. NXP does not convey any license under its patent rights nor the rights of others. NXP sells products pursuant to standard terms and conditions of sale, which can be found at the following address: nxp.com/SalesTermsandConditions.

While NXP has implemented advanced security features, all products may be subject to unidentified vulnerabilities. Customers are responsible for the design and operation of their applications and products to reduce the effect of these vulnerabilities on customer's applications and products, and NXP accepts no liability for any vulnerability that is discovered. Customers should implement appropriate design and operating safeguards to minimize the risks associated with their applications and products.

NXP, the NXP logo, NXP SECURE CONNECTIONS FOR A SMARTER WORLD, COOLFLUX, EMBRACE, GREENCHIP, HITAG, I2C BUS, ICODE, JCOP, LIFE VIBES, MIFARE, MIFARE CLASSIC, MIFARE DESFire, MIFARE PLUS, MIFARE FLEX, MANTIS, MIFARE ULTRALIGHT, MIFARE4MOBILE, MIGLO, NTAG, ROADLINK, SMARTLX, SMARTMX, STARPLUG, TOPFET, TRENCHMOS, UCODE, Freescale, the Freescale logo, Altivec, C-5, CodeTEST, CodeWarrior, ColdFire, ColdFire+, C-Ware, the Energy Efficient Solutions logo, Kinetis, Layerscape, MagniV, mobileGT, PEG, PowerQUICC, Processor Expert, QorIQ, QorIQ Qonverge, Ready Play, SafeAssure, the SafeAssure logo, StarCore, Symphony, VortiQa, Vybrid, Airfast, BeeKit, BeeStack, CoreNet, Flexis, MXC, Platform in a Package, QUICC Engine, SMARTMOS, Tower, TurboLink, UMEMS, EdgeScale, EdgeLock, eIQ, and Immersive3D are trademarks of NXP B.V. All other product or service names are the property of their respective owners. AMBA, Arm, Arm7, Arm7TDMI, Arm9, Arm11, Artisan, big.LITTLE, Cordio, CoreLink, CoreSight, Cortex, DesignStart, DynamIQ, Jazelle, Keil, Mali, Mbed, Mbed Enabled, NEON, POP, RealView, SecurCore, Socrates, Thumb, TrustZone, ULINK, ULINK2, ULINK-ME, ULINK-PLUS, ULINKpro, μ Vision, Versatile are trademarks or registered trademarks of Arm Limited (or its subsidiaries) in the US and/or elsewhere. The related technology may be protected by any or all of patents, copyrights, designs and trade secrets. All rights reserved. Oracle and Java are registered trademarks of Oracle and/or its affiliates. The Power Architecture and Power.org word marks and the Power and Power.org logos and related marks are trademarks and service marks licensed by Power.org.

© NXP B.V. 2020.

All rights reserved.

For more information, please visit: <http://www.nxp.com>

For sales office addresses, please send an email to: salesaddresses@nxp.com

Date of release: 07/2021

Document identifier: 3PPMSMCRUG

